

# Editor Manual



floor  planner

# Floorplanner Editor Manual

---

1 Overview

2 Canvas

a 2D view

b View Settings

3 3D view

4 Camera view and Renders

5 Sidebar

6 Floor menu

7 Build:

a Walls and Rooms

b Surfaces

c Doors and Windows

d Structures

e Tekst

f Lines

g Dimension lines

h Room types

i Symbols

j Tape measure

k Light settings

l Backdrop Drawing

m Dimension settings

m Mirror / Rotate plan

8 Decorate tools:

a Colors

b Materials

9 Furniture

a Furniture

b Categories

c Collections

10 Project actions

a Export 2D

b Export 3D

c Embed

d Collaborate

e Download

11 Keyboard shortcuts

12 Troubleshooting

13 More Help

# 1 Overview

Below you see the floorplan editor. In this tool you draw your floorplan, add doors, windows, and other architectural elements. You can label your rooms and add furniture.

The screenshot shows the floorplanner editor interface with several components labeled:

- Sidebar:** A vertical panel on the left containing icons for drawing walls, doors, windows, furniture, and other architectural elements.
- Zoom:** A vertical panel with plus (+) and minus (-) icons for zooming in and out, and a target icon for resetting the view.
- Floor menu:** A dropdown menu at the top left showing the current floor, "Ground floor".
- Camera view:** A camera icon at the top center for switching between different camera perspectives.
- Canvas:** The main workspace where the floorplan is drawn, featuring a grid and dimension lines.
- Undo / Redo:** A pair of arrows at the top right for undoing and redoing actions.
- Save:** A "Save" button at the top right.
- Actions:** A dropdown menu at the top right for additional actions.
- Exit to Dashboard:** A close button (X) at the top right.
- 2D / 3D view:** A panel with "2D" and "3D" buttons for switching between 2D and 3D views.
- View settings:** A gear icon for accessing view settings.

The floorplan itself shows a layout with rooms labeled: Living, Kitchen, Hallway, Toilet, and Patio. Dimensions are provided for various sections, such as 6.00 m and 3.85 m for the top width, and 4.17 m, 2.83 m, 2.21 m, 2.24 m, 5.40 m, and 10.60 m for the bottom width. The floorplanner logo is visible in the bottom right corner of the canvas.

# 2a Canvas, 2D view

In your canvas you draw walls, rooms, lines etc. Other items can be dragged and dropped.

## Main navigation

To pan, click and drag your left mouse button on an empty space in the canvas, or on empty spot on a surface. Use your mousewheel to zoom in and out.

## Selecting and deselecting

Click on objects to select them. This will activate the sidebar, and sometimes give some handlers and buttons in the canvas. Click anywhere in the canvas to deselect,

or press **esc** on your keyboard.



## 2D View settings

See this page



## Interactive Snapping

When drawing or dragging items you will often snap to other items in your canvas.

Hold **S** to temporarily disable snap.

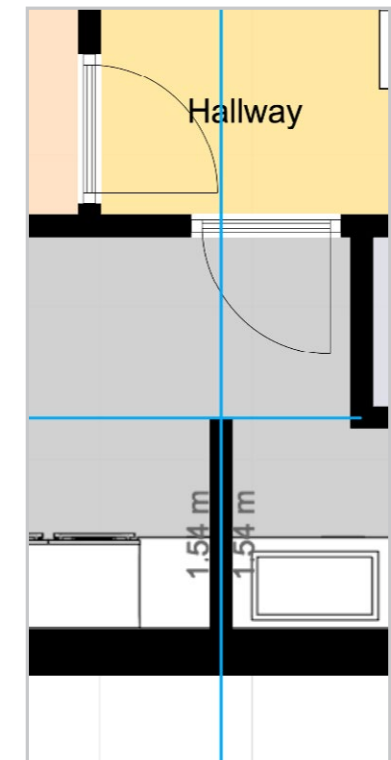

# 2b Canvas, View settings

In your canvas you draw walls, rooms, lines etc. Other items can be dragged and dropped.

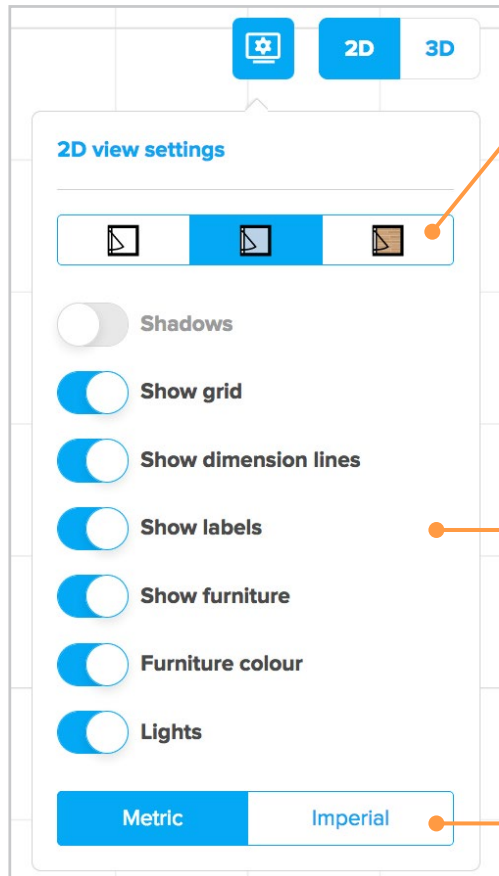

Set 2D view:

Toggle any elements on or off.

Set units to Meter or Feet



**Black and white**  
All surfaces appear in white. All furniture as black and white outlines

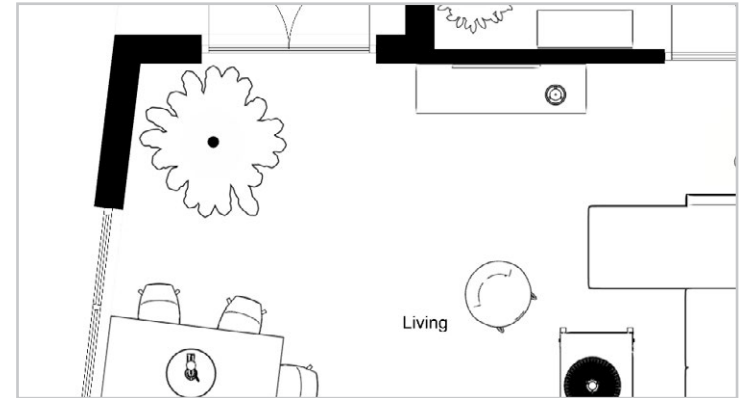

**Colored outline**  
All surfaces appear in plain color. All furniture as black and white outlines

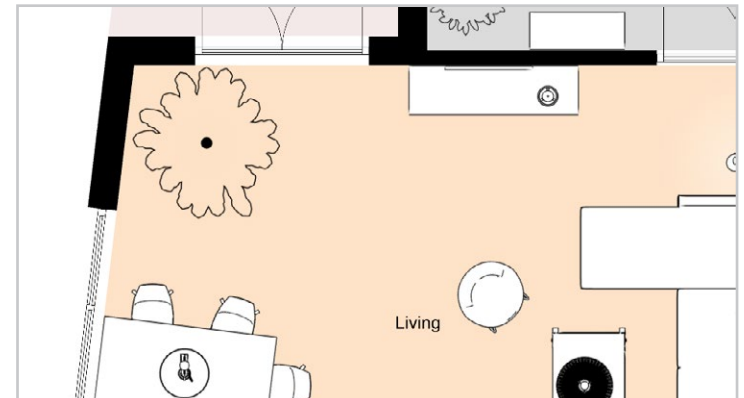

**Material and shadows**  
All surfaces appear in selected materials. All furniture in their real materials. Walls and furniture have a light dropshadow. Lights cast light.



# 3 3D view

In floorplanner you can get a 3D preview of your plan. NB: with 3D exports and camera renders, you can get much higher quality images. See chapter 7 and chapter 11b



## 3D View navigation

Click and drag in the canvas to rotate your view around the focal point. Use your scroll wheel to zoom in or out.

Use to shift the camera position to the front/back right or left.

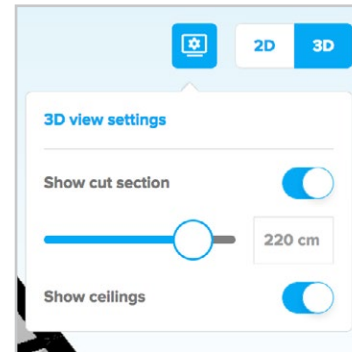

## 3D View settings

With the Cut section on, you choose to hide walls, doors and windows above a chosen height.

Show ceilings can be set on, in that case, when your camera is inside a room, a ceiling is shown. (see below) These are generated automatically.

*Tip: if you have different wall heights this can give problems. Better use custom surfaces with an elevation in that case.*

Zooming in far enough will give a view inside a room.



# 4 Camera view and renders

The camera tool lets you create realistic images of your rooms. You can use this for virtual staging of your house, or for interior design presentations



Upload a scenery image. This will show up outside your windows. It has to be a jpeg image. Best is to use images in a 16:9 ratio, on a high resolution

## Main navigation

To turn your view, click and drag your left mouse button in the screen.

Use your mousewheel to zoom in and out.

Use your arrow keys to move the camera forwards, backwards, left or right.

Use this slider to adjust the altitude of the camera.

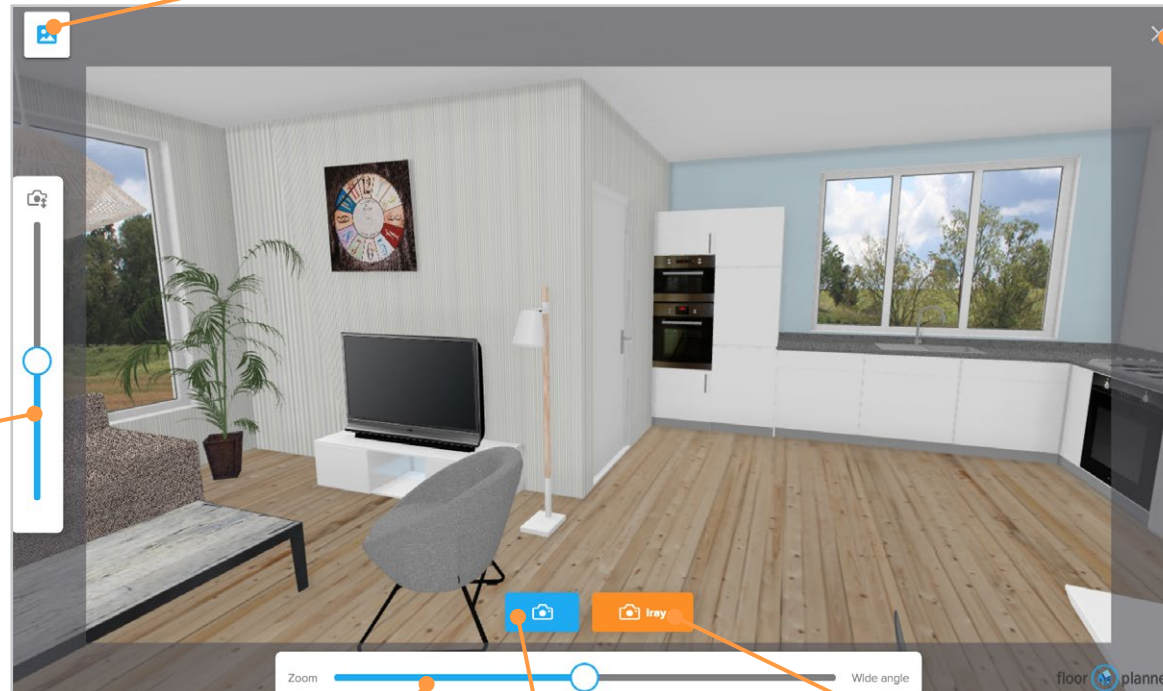

back to 2D view

Use this slider to adjust the camera angle, this will change the focal point.



Click the camera button to create a 3D render of this view.  
Free:SD render Pro:HD Render  
You'll switch to 2D mode and the image will be sent to the email you have in your account, or what is entered in the export menu.

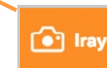

Coming soon  
A paid option to render in Iray quality. See on the next page a result of normal and Iray camera renders.

# 4 Camera view and renders



An example  
a 3D photo

Iray Rendering (coming soon): This will give  
even better detailing, lighting and reflection.



# 5 The Sidebar: Build, Decorate, Furnish

The sidebar is the main area where all the tools can be found to create and detail your floorplan and interior design. There are 3 tabs, or modes: Build, Decorate and Furnish

## Build

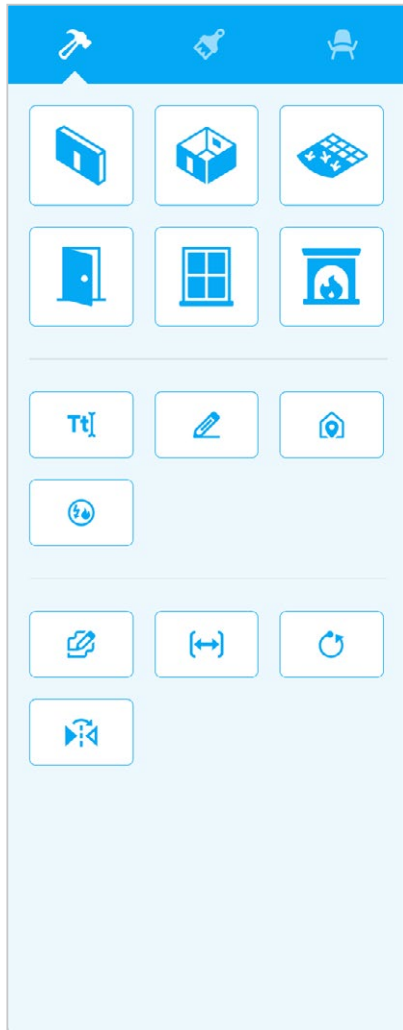

Draw walls  
Draw rooms  
Surfaces  
Doors  
Windows  
Structures

Tekst  
Lines or Dimension lines  
Room labels  
Symbols and Icons

Background drawing  
Dimension settings  
Rotate entire plan  
Mirror entire plan

## Decorate

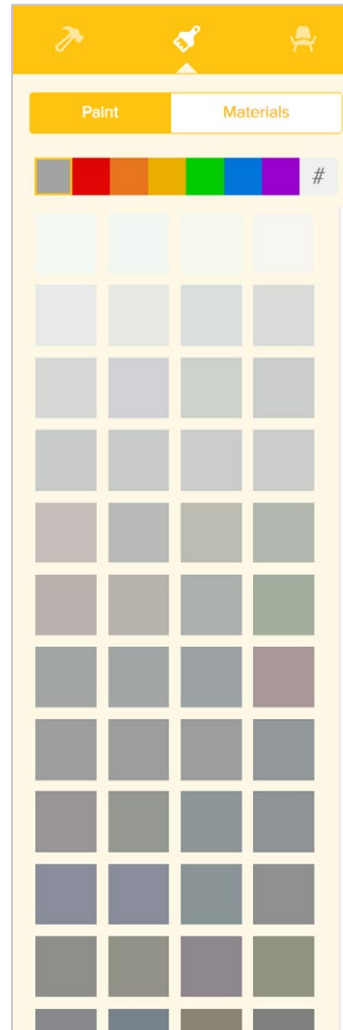

Find colors  
or materials, and  
apply them to a  
room, wall or  
surface.

## Furnish

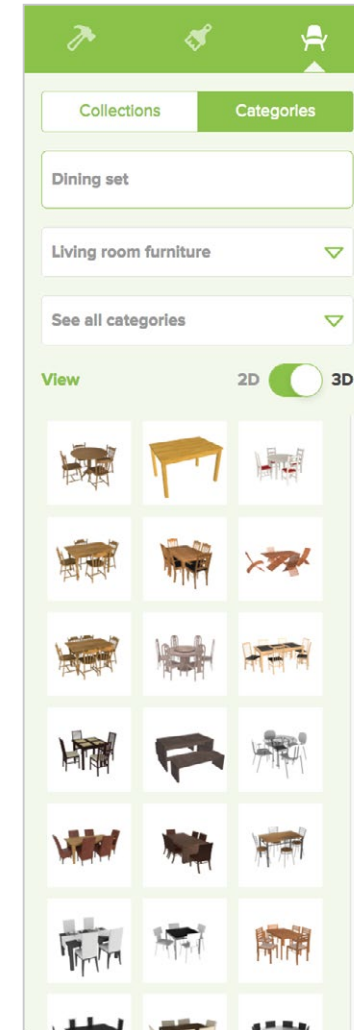

Search through our  
libraries of items  
by category or use  
our premade style  
collections.

# 5 The Sidebar for selected objects (wall)

When you've selected an item, for instance a wall segment, the sidebar will show info about this item. In build mode, you can edit the wall size properties.

Switching the side bar to decorate mode will show the colors or materials applied to this wall segment.

Clicking on the furnish icon will show wall related furniture. You can drag and drop these on your wall.

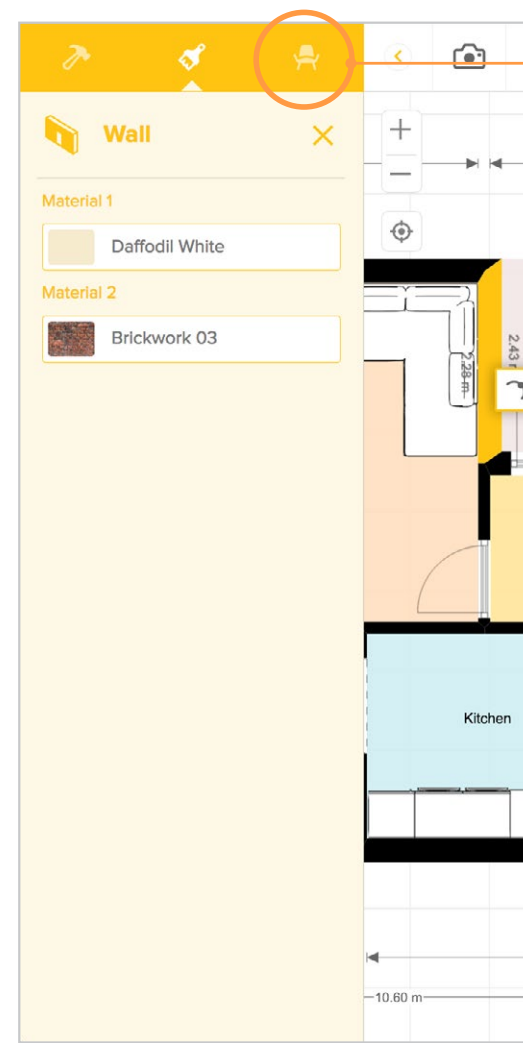
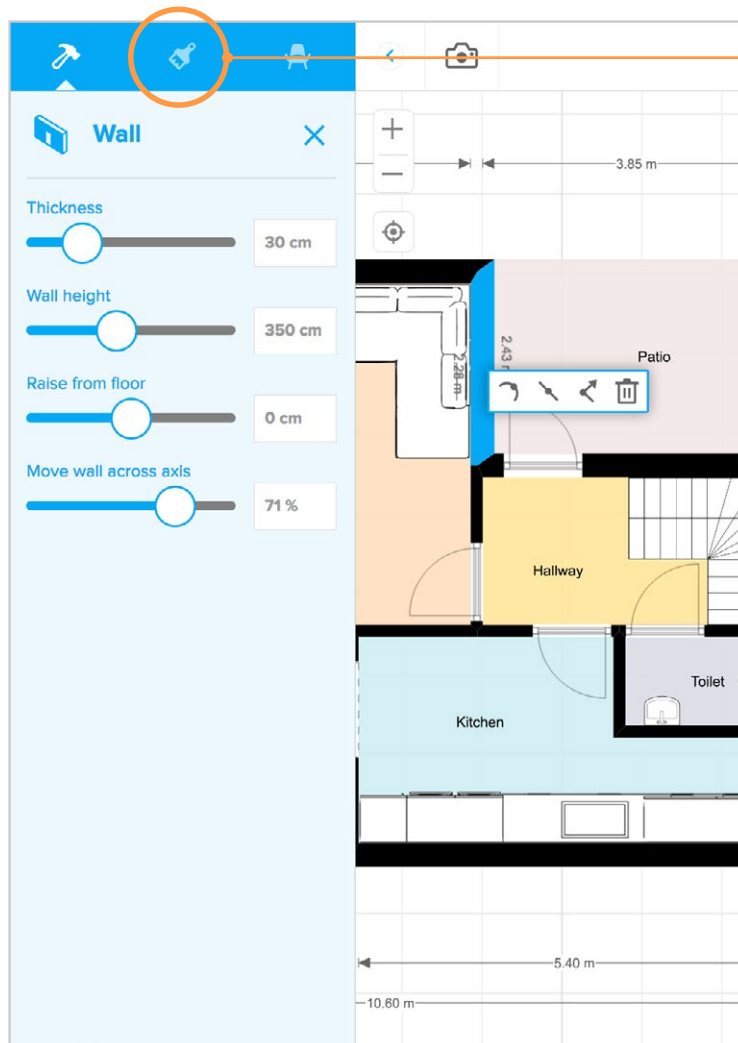

# 6 The Floor menu

Buildings usually have multiple floors. Each floorplanner project represents one house or another kind of property. The floor menu is the place where you can add and manage your floors.

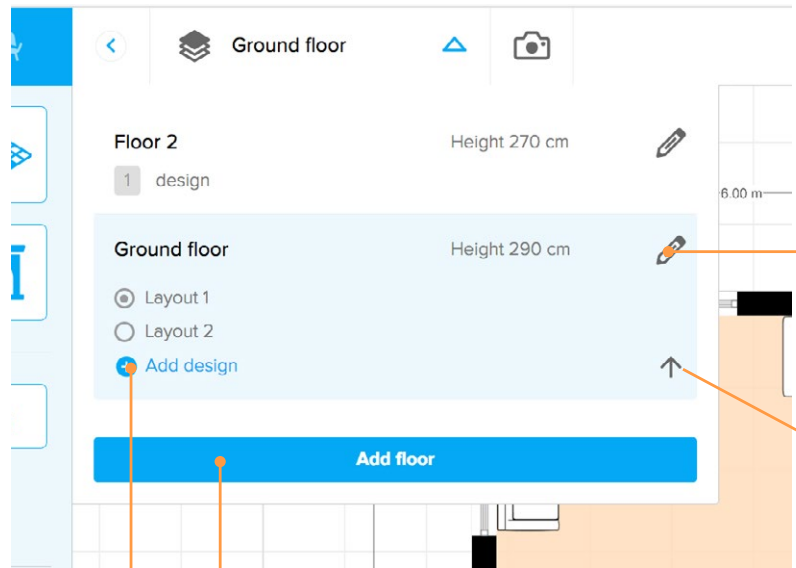

### Add a new floor

You can start a floor from scratch or you can duplicate a floor you already drew in this project.

### Add a new design.

Each floor can have multiple designs, variants in the interior design or floor layout.

You can start a design from scratch or you can duplicate a design you already drew in this project.

Move floor up or down

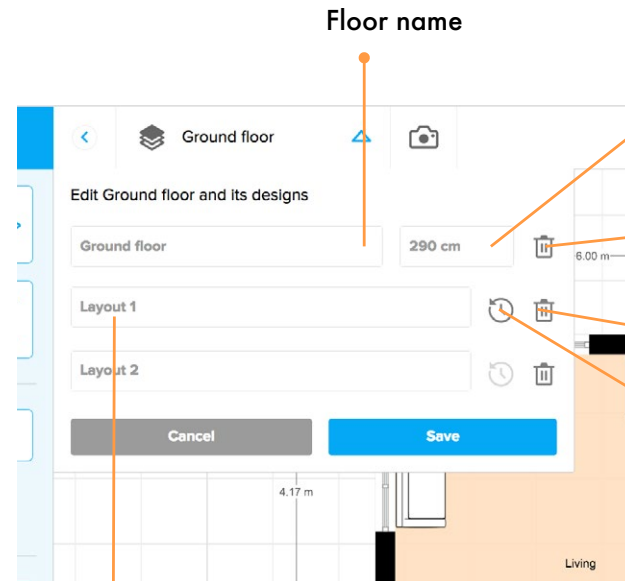

Floor name

Design name

Change the default wall height for all walls in this floor. This applies to all walls you draw in this floor and all walls you've drawn in each design in this floor.

Remove floor and all designs in it.

Remove floor and all designs in it.

Show version history of this design. Did you break anything in your last save? Then you can use this to retrieve an earlier version.

You can add a design and create duplicates of a floor layout. This way you can play with the interior style or interior layout in each floor like in the example below. See also the chapter on furniture collections



interior in urban style



interior in industrial style



interior in contemporary style

# 7a Build: Walls and Rooms

In floorplanner you can draw your floorplan by drawing wall by wall, or room by room. A space enclosed by walls becomes a room, and is given a room surface automatically.

## Draw Wall by Wall

1) Click the draw room icon and setup your wall thickness and height.

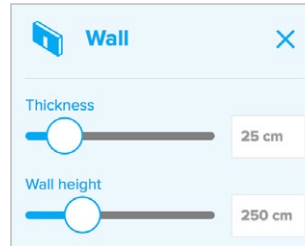

2) Click in the canvas and drag your mouse in the direction you want your wall.

Release where you want your wall to end or type in your desired length and press Enter.

Tip: the blue circle indicates your wall thickness.

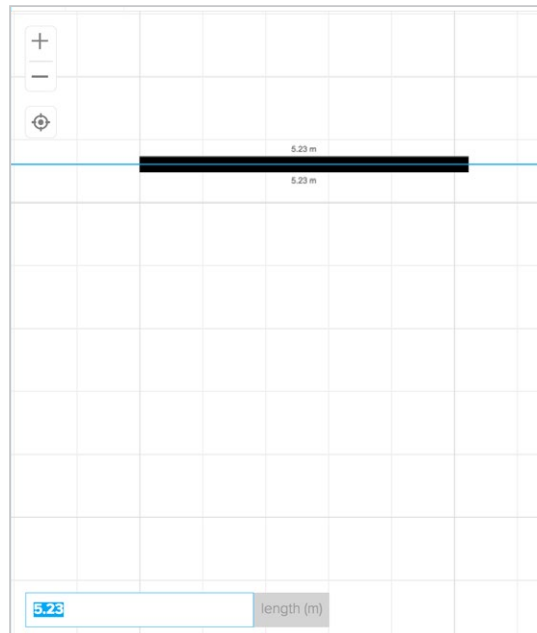

3) Repeat this to any corner of your room.

Tip: guidelines will help you find the end of a room or vertical or horizontal direction

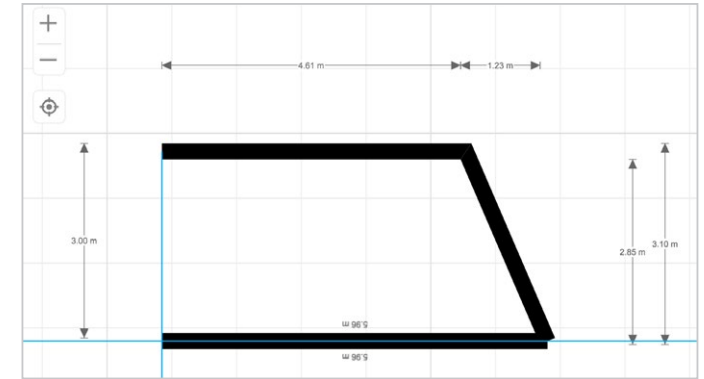

4) Close the room by starting on the starting point. A room surface will appear.

NB: Keep in mind that wall thickness affects the wall length when going around a corner.

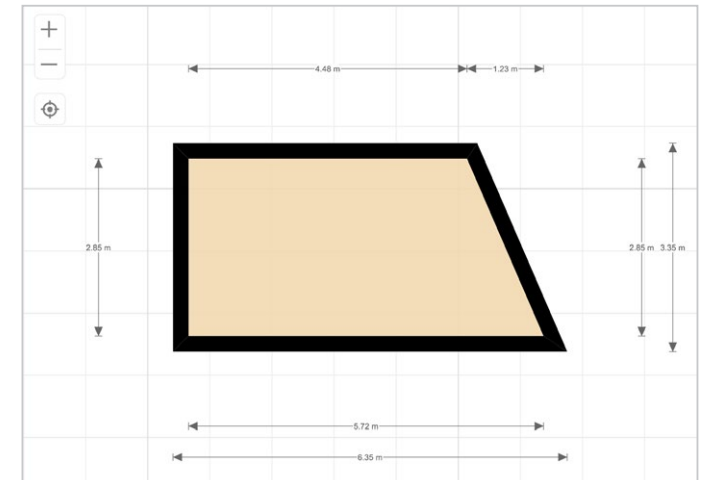

You can also use this tool to draw separate wall segments.

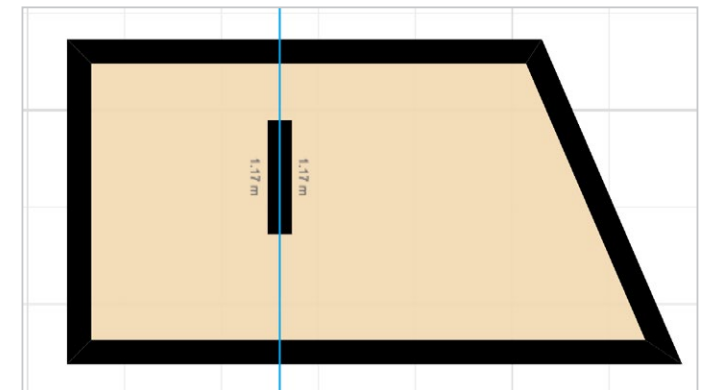

# 7a Build: Walls and Rooms

You can draw quicker room by room.

## Draw Room

1) Click the draw room icon and setup your wall thickness and height.

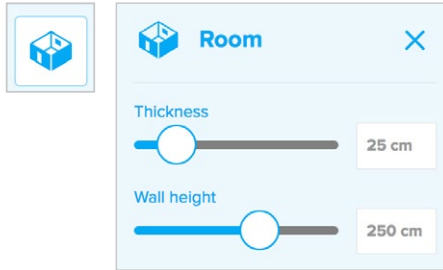

0.25, 2.5 thickness, height (m)

2) Click in your canvas and drag your mouse towards the direction and size you want your room to be.

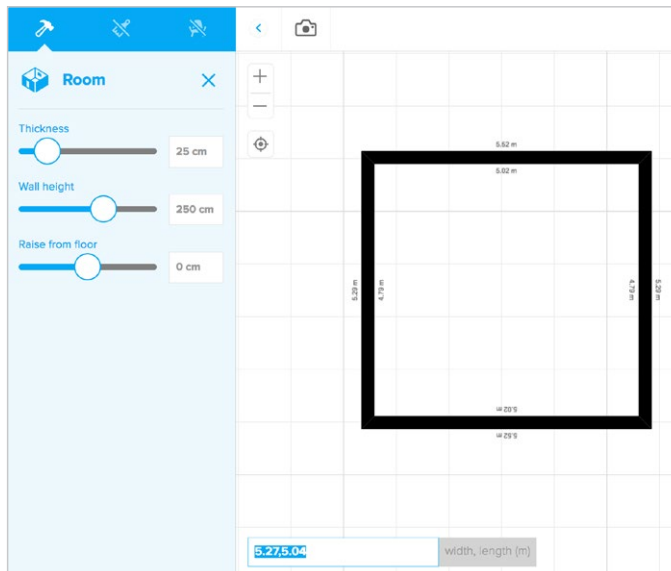

3) Release your mouse. You'll get automatic dimensions showing the interior room dimensions and exterior dimensions.

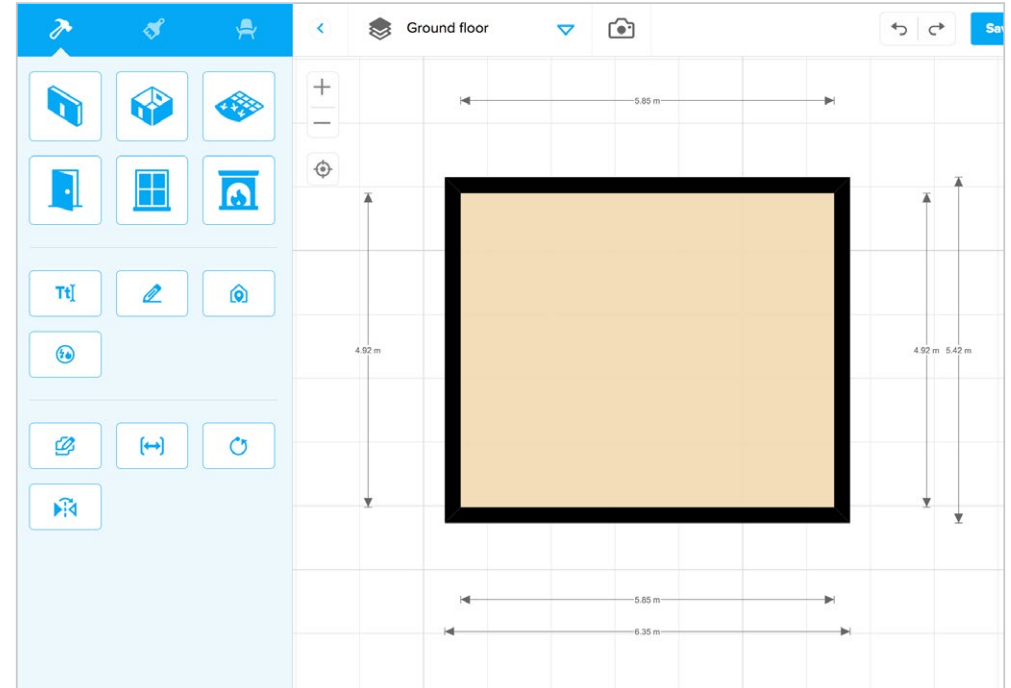

4) You can click the inner dimensions to set the exact room size. Click the arrows to indicate which wall should move.

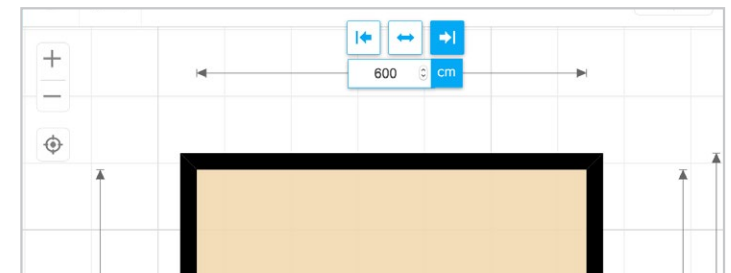

# 7a Build: Walls and Rooms

Walls are very interactive elements. You can adjust your room shape by splitting and dragging walls or wall corners. In a few examples we explain the basic functionality.

## Create an alcove

1) Click on a wall segment, and press this icon to split the wall

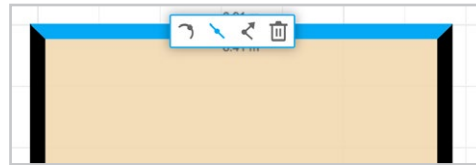
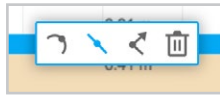

2) Click a bit further on a wall segment, and press this icon to split the wall again

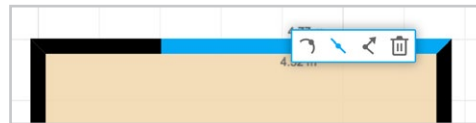

3) Now you can click and drag the new wall segment in the middle. Release your mouse to form your alcove.

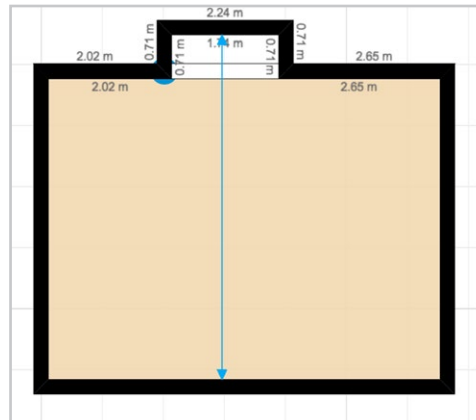

*Tip: the blue arrow indicates the distance to the opposite wall. While you are dragging, you can type in the size this distance should have, and confirm by ENTER. That's a quick way to get an exact dimension.*

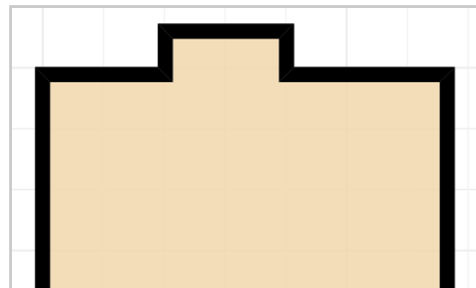

## Create a wall on an angle

1) Move your mouse over a wall corner, click and drag it to change the wall angle.

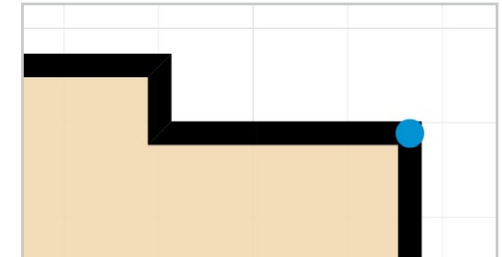

2) Release the corner wherever you want.

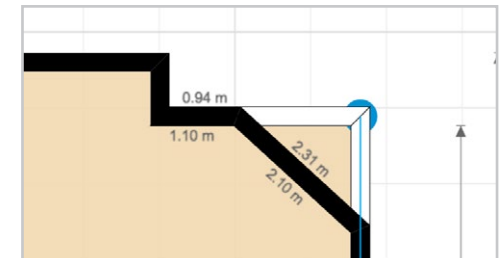

## Create a curved wall

1) Click a wall segment. Then click the curve icon and move your mouse to curve the wall.

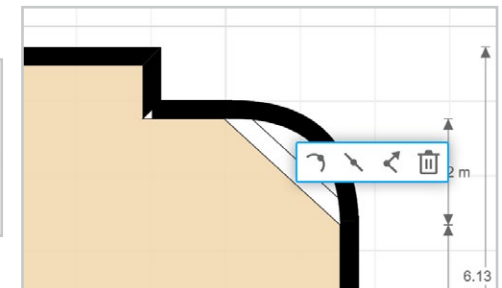
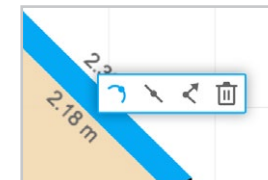

2) Release your mouse when you're satisfied with the curve.

*Tip: to uncurve the wall, click the curve icon again and move your mouse. The wall will snap to a straight line.*

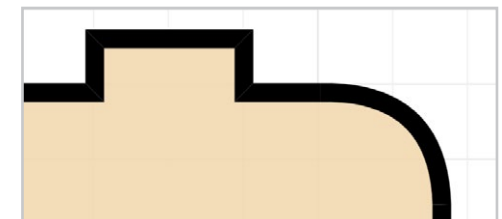

# 7a Build: Walls and Rooms

## Draw wall from point

1) click on a wall segment where you want to start a wall. Then click the third icon.

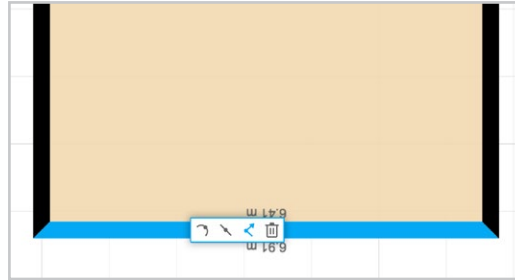

2) Move your mouse to where you want your wall to end and click again.

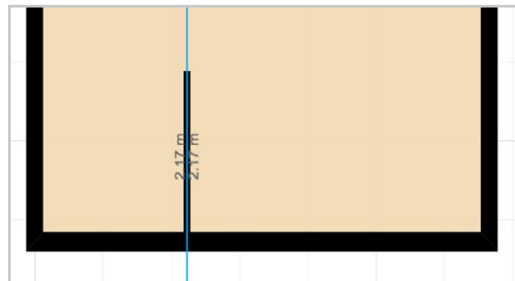

## Removing a wall segment

1) Click on a wall segment, and press the fourth icon to remove the segment.

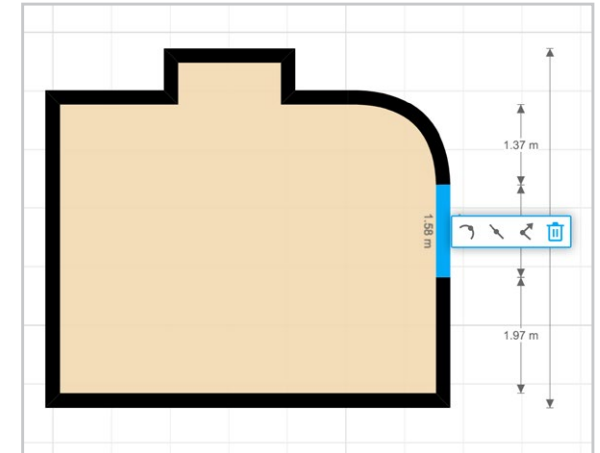

2) If the space is not enclosed anymore by this action, the floor will disappear. If two rooms are connected this way, the two separate floors merge into one.

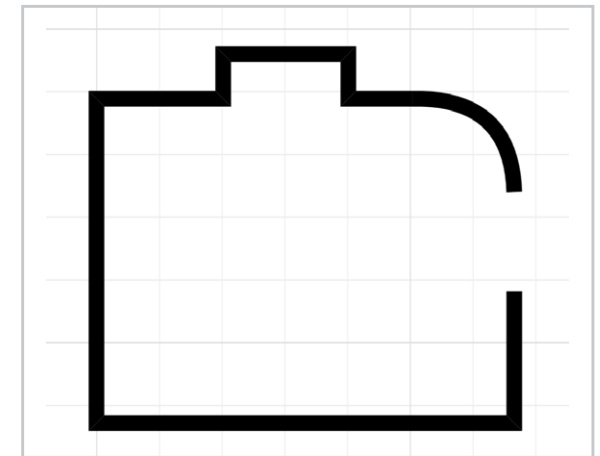

# 7a Build: Walls and Rooms

When working with different wall thicknesses, you may encounter situations when the wall inside a room jumps due to this thickness difference. To solve this, we've introduced an option to move the wall perpendicular to the axis.

## Move wall across axis

1) Click on the thickest wall segment that creates a jump.

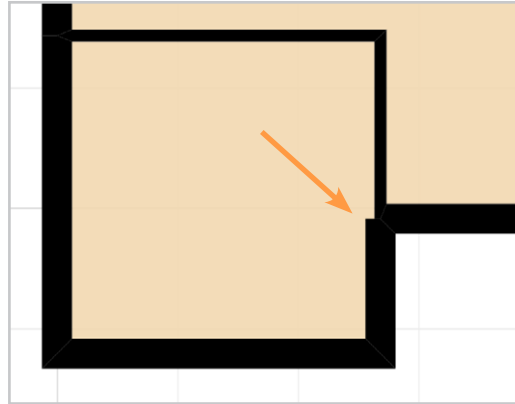

2) Move the slider called *move wall across axis*

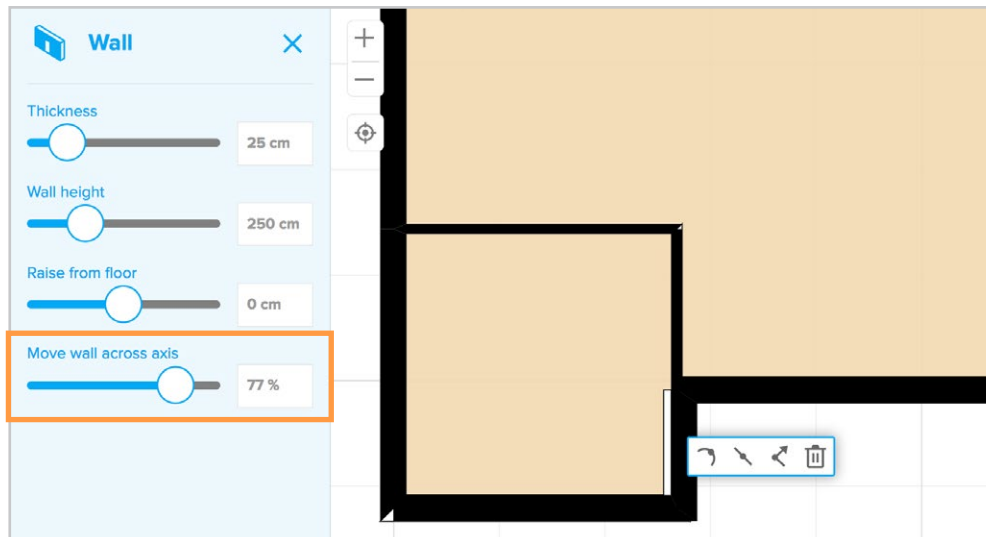

3) Then hit Escape or click the cross to exit the wall menu. Your change will be applied.

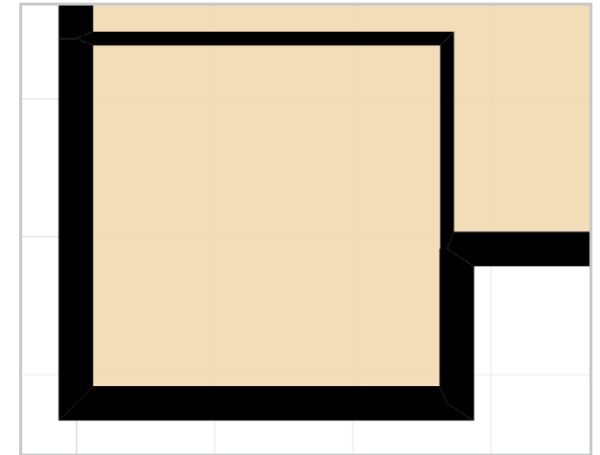

# 7a Build: Walls and Rooms: Wall corners: create sloped walls

Drawing sloped walls is done by adjusting the height of wall corners

## Drawing room

1) First draw the exterior walls of your floor plan.

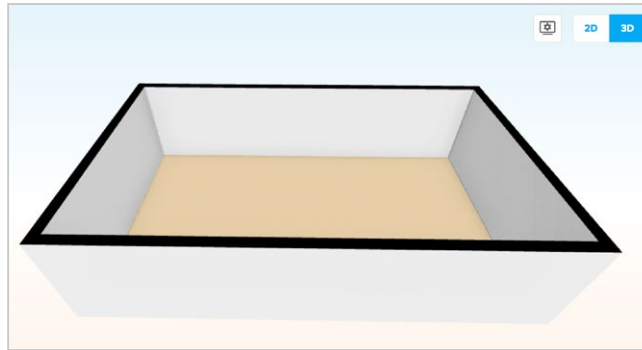

2) Click in the canvas and drag your mouse in the direction you want your wall.

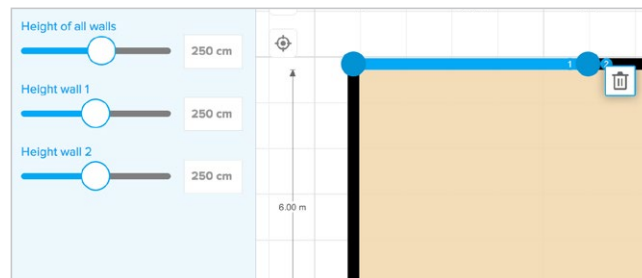

3) Repeat this to any corner of your room.

*Tip: guidelines will help you find the end of a room or vertical or horizontal direction*

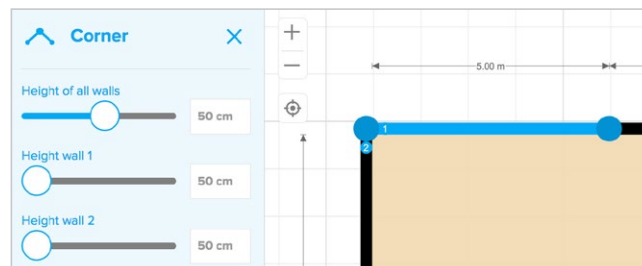

4) View 3D to see the result

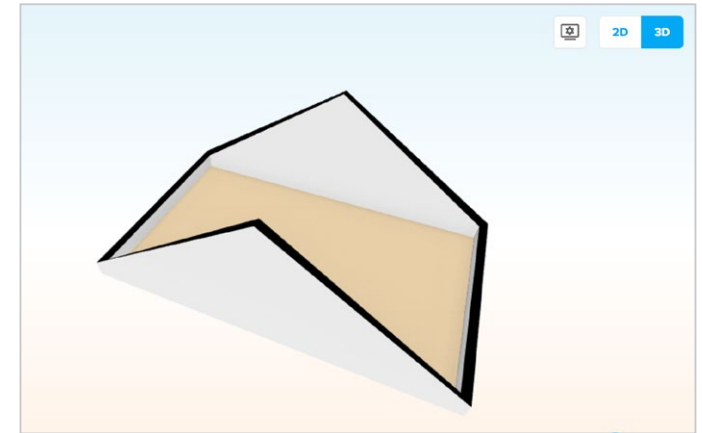

5) After setting the correct slope for the exterior walls, use the wall by wall tool to create your inner rooms.

*Tip: Start and end each room on an exterior wall if possible. The walls you draw will inherit the wall height at the point where you connect with the exterior walls.*

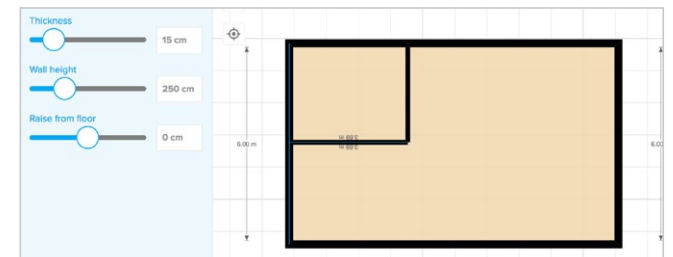
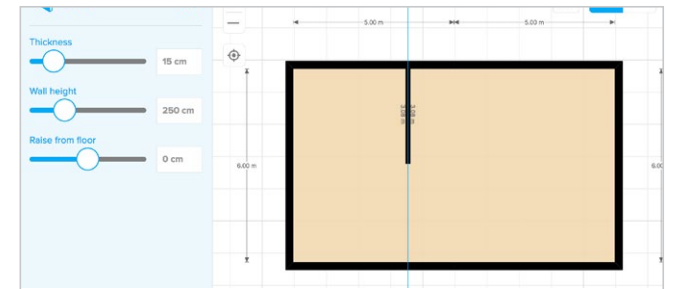

4) View 3D to see the result

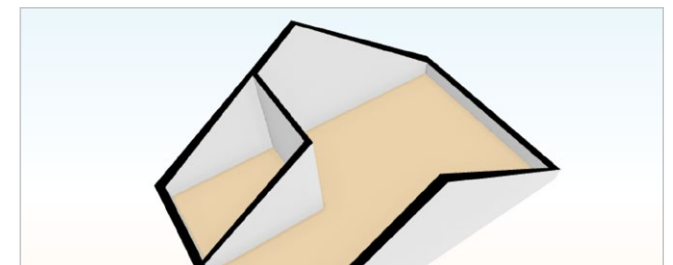

# 7b Build: Surfaces

To create a surface without walls, we have a surface tool. You can create surface shapes for various purposes. For instance for outdoor spaces, for areas within your room, to create sloped surfaces like roofs or to create a hole in a floor (for downward stairs).

## Draw a surface shape

1) Click the surface room icon and choose your surface type you want to draw (optional)

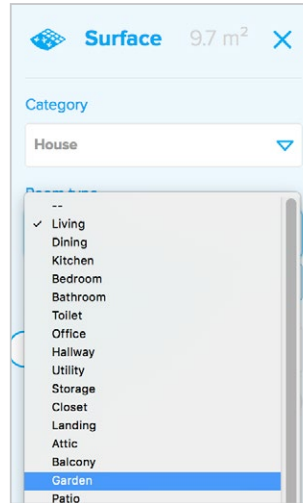

2) Click and drag on each place in the canvas where you want a surface corner.

Tip: To have an exact edge length, type in the desired size and hit ENTER.

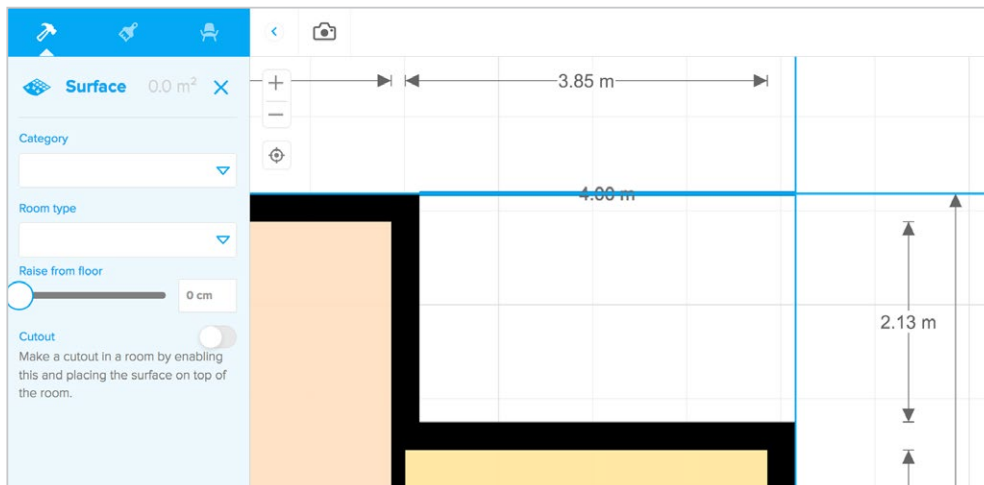

3) To finish your surface, on the first point or press ESC on your keyboard.

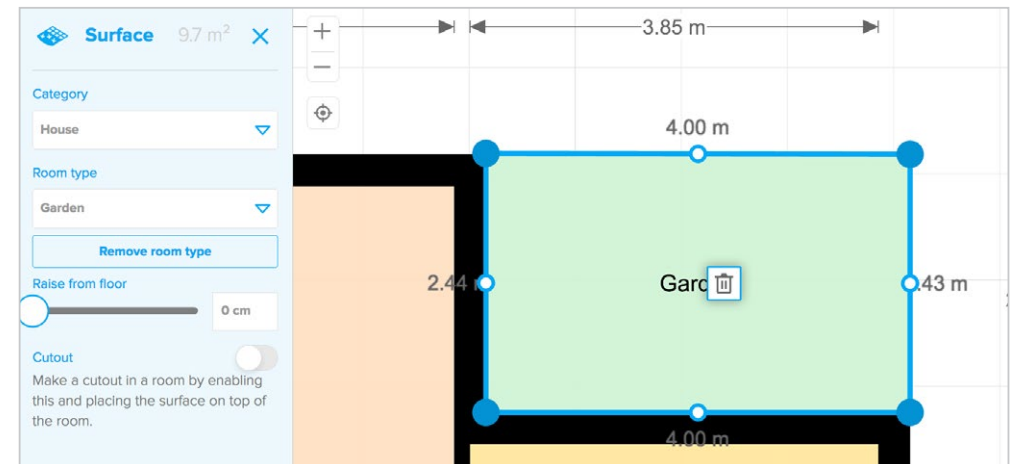

4) You can drag edges and corners to reshape your surface, or drag the white dots to create a curved edge.

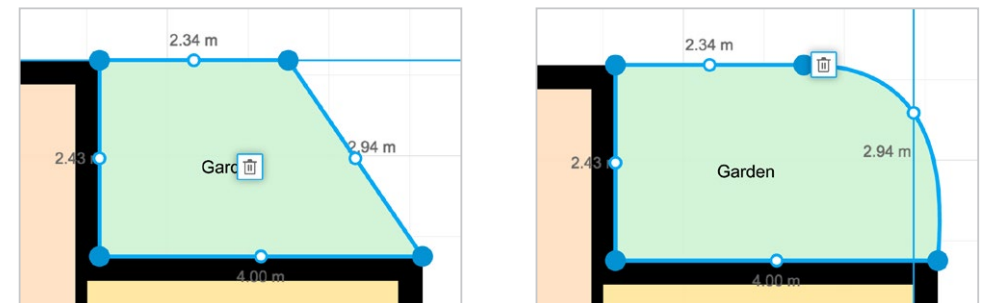

5) Click on a surface edge to add a corner. Click on a corner to remove or edit the height.

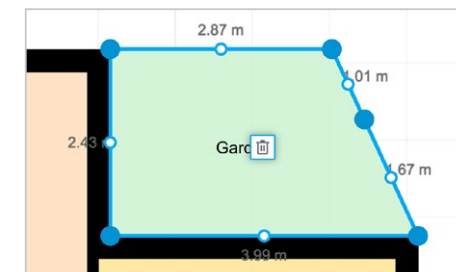

# 7b Build: Surfaces: sloped and elevated surfaces

Surfaces are drawn by default on floor level. In some cases you want a surface at a higher level, or a sloped surface. For instance for gardens, for custom ceilings or roofs.

## Sloped surface

Click the surface shape you drew. Then click on each corner that should have an elevation and move the raise slider in the sidebar.

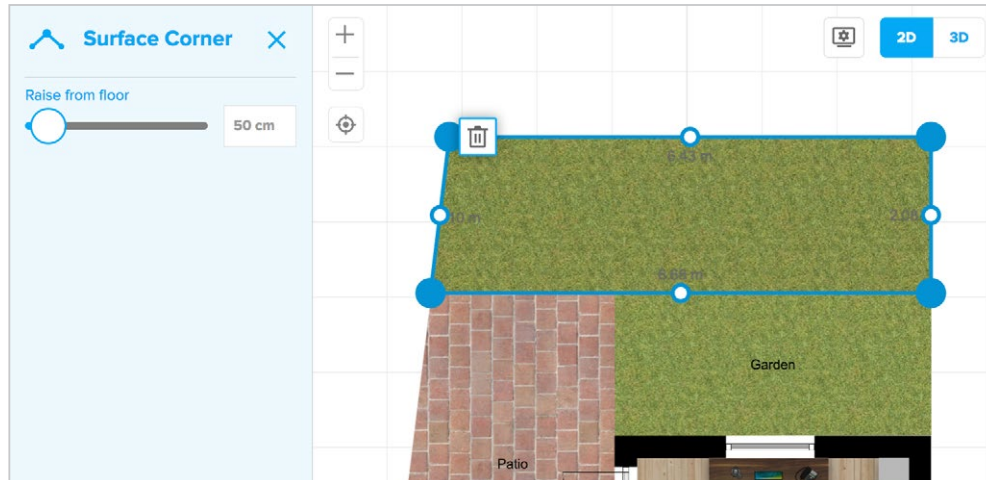

Click 3D to check out how it looks



## Elevated surface

Click the surface shape you drew. Use the raise slider in the sidebar to raise the entire surface to the desired height.

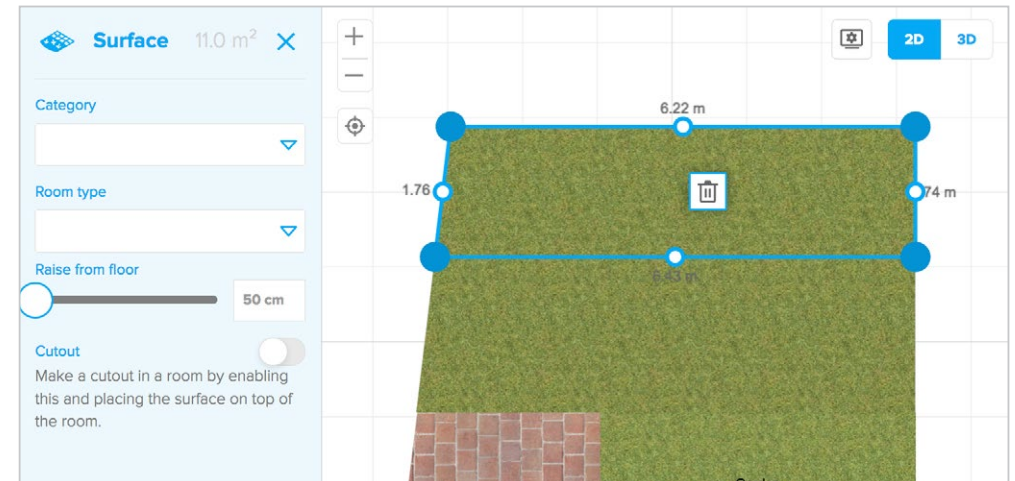

Click 3D to check out how it looks



*Tip: divide your sloped surfaces in parts to make sure the 3D geometry will display correctly. Use separate rectangles or triangles next to each other for each section that has a slope.*

# 7b Build: Surfaces: cutouts

---

*With surfaces you can create a hole in the floor to have for instance a staircase coming up from the floor below.*

more will follow

# 7b Build: Surfaces: sloped ceilings

Follow these steps to create a sloped ceiling in your room with a correct ceiling surface.

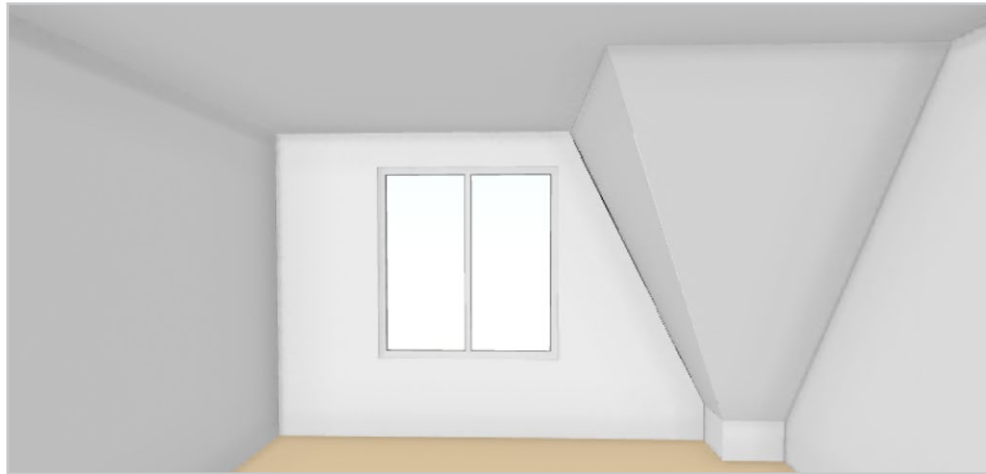

2 Lower the wall corners where necessary.

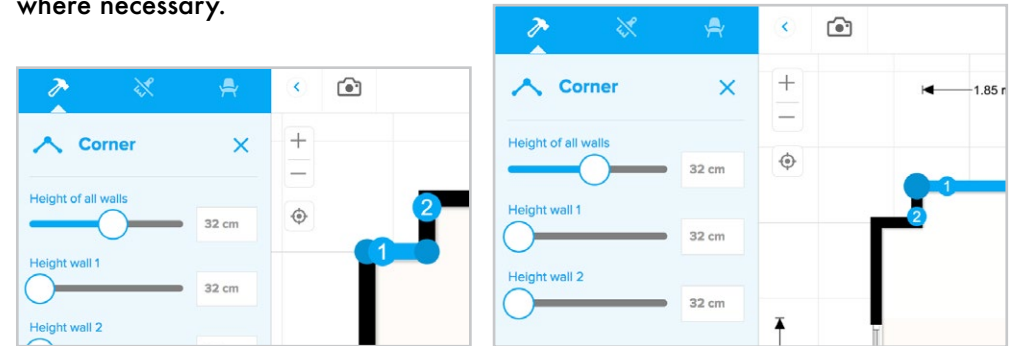

1 Draw a room, split the walls where they should start to go downwards.

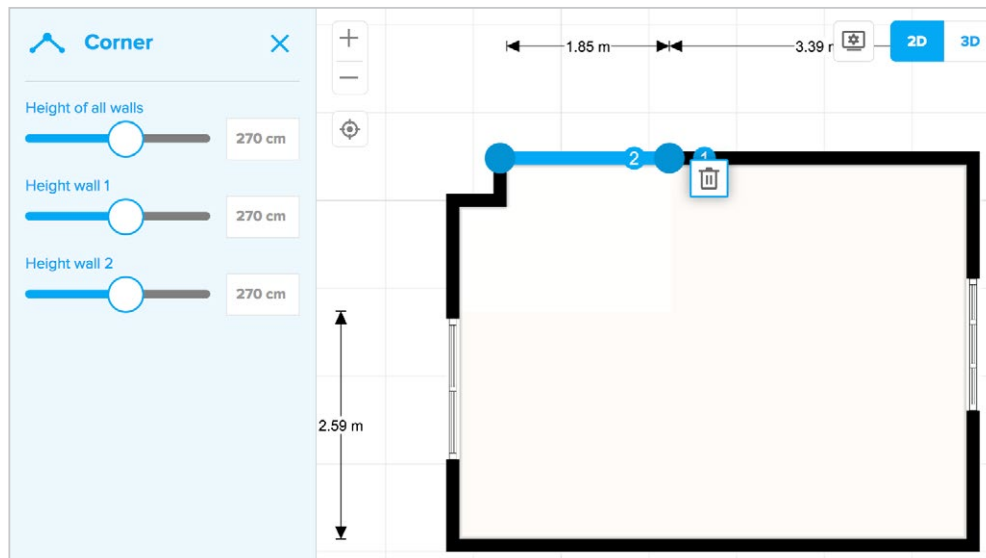

3 Check the 3D view: you see that the automatic ceilings is showing up incorrectly. Check this option off in the 3D view settings. We'll draw them manually.

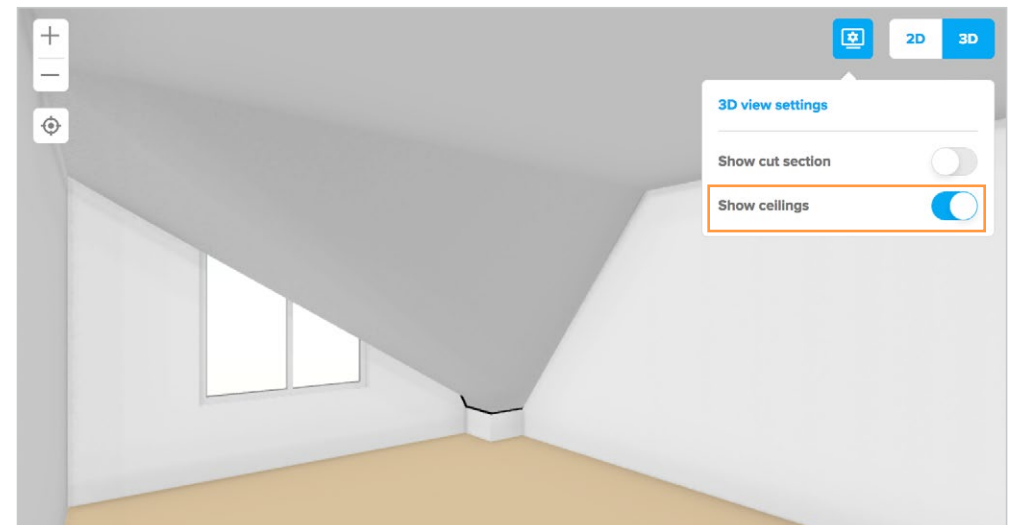

# 7b Build: Surfaces: sloped ceilings

4 Draw the first sloped ceiling surface. Click the corners that should be low, and set the elevation.

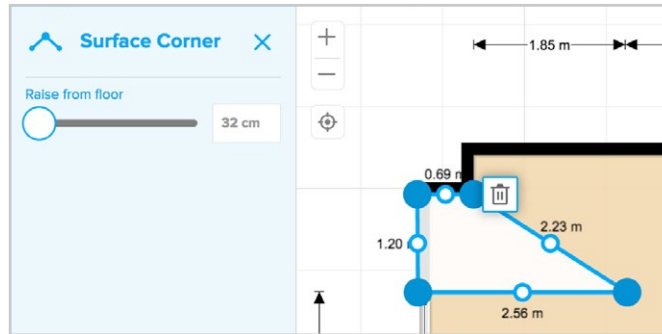

Do this for the high corners too.

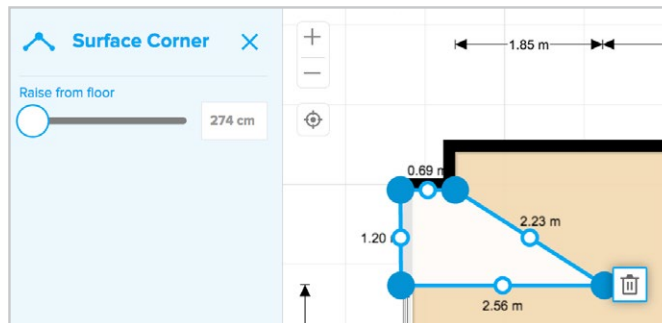

5 Draw the second sloped ceiling surface. Click the corners and raise them to the desired height.

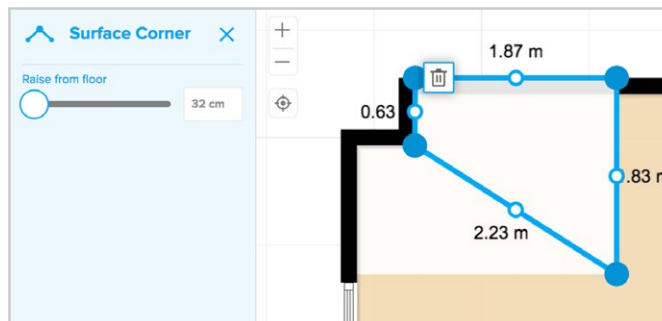

6 Now we'll create the ceiling surface manually. Draw a surface covering the entire room. Select it and give it an elevation at your wall level.

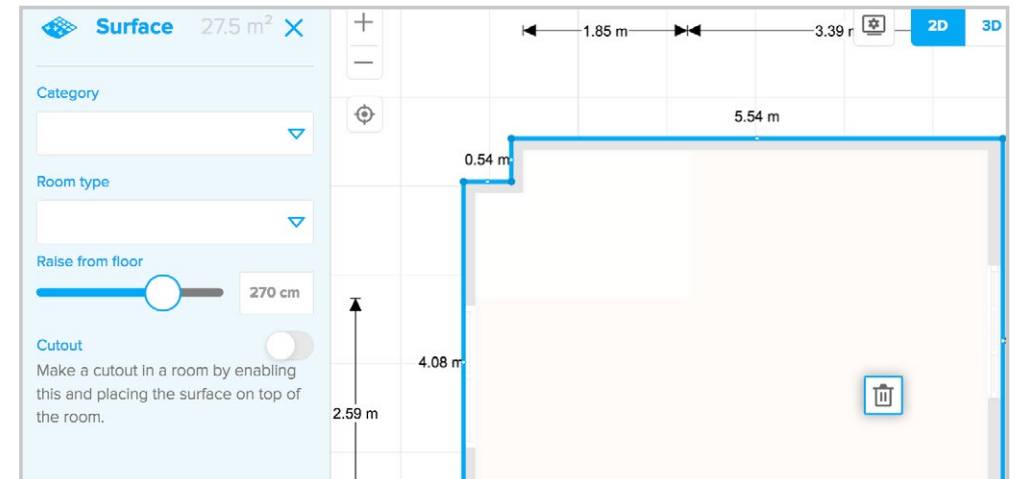

7 Click the camera icon or 3D icon.

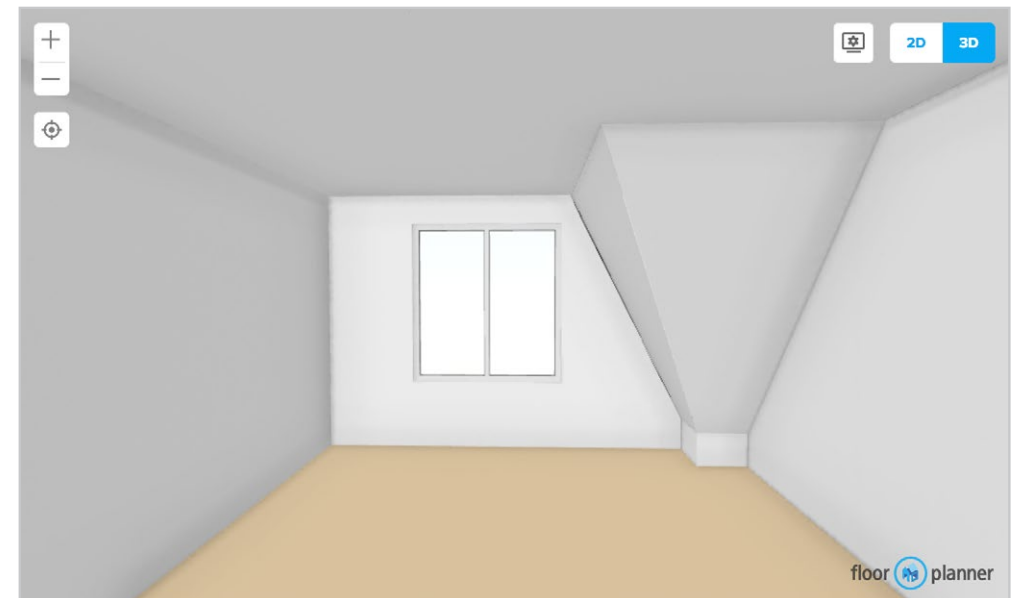

# 7c Build: Doors and Windows

Doors and windows are placed on a wall, and can be modified in size. They work in the same way.

## Adding doors

1) Click on the doors or windows icon

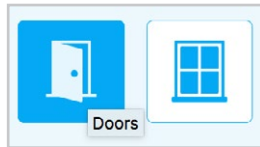

2) You can view the list of doors or windows in 2D top view or 3D view.

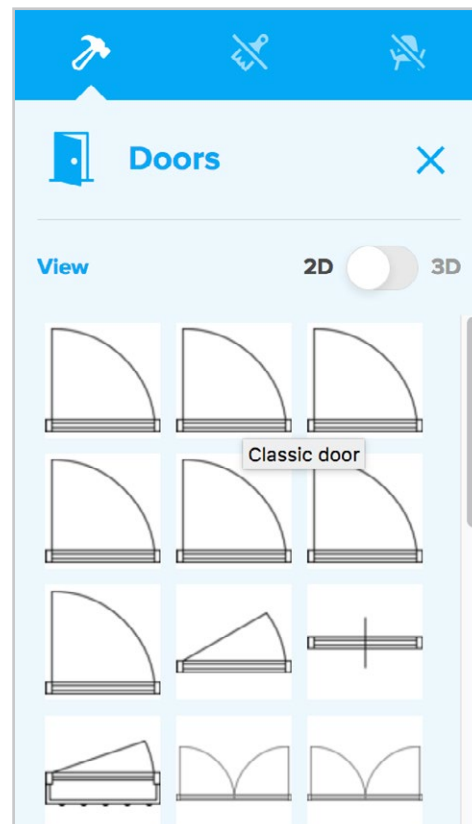
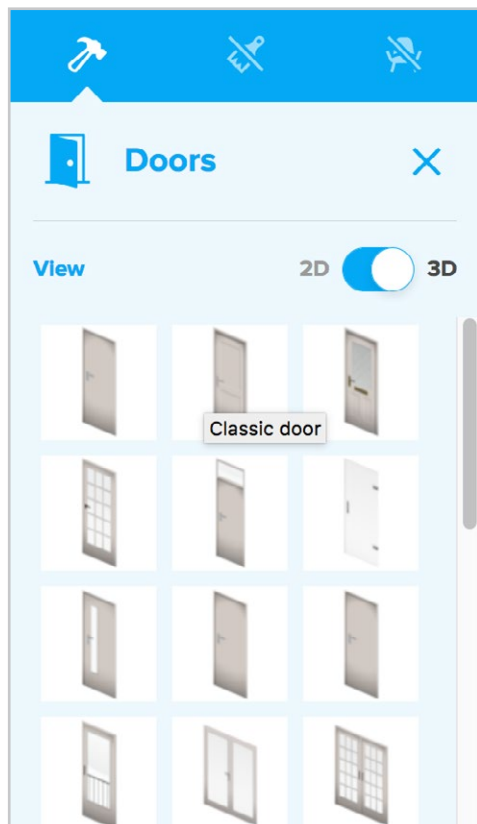

3) From the list, drag and drop your door or window onto a wall.

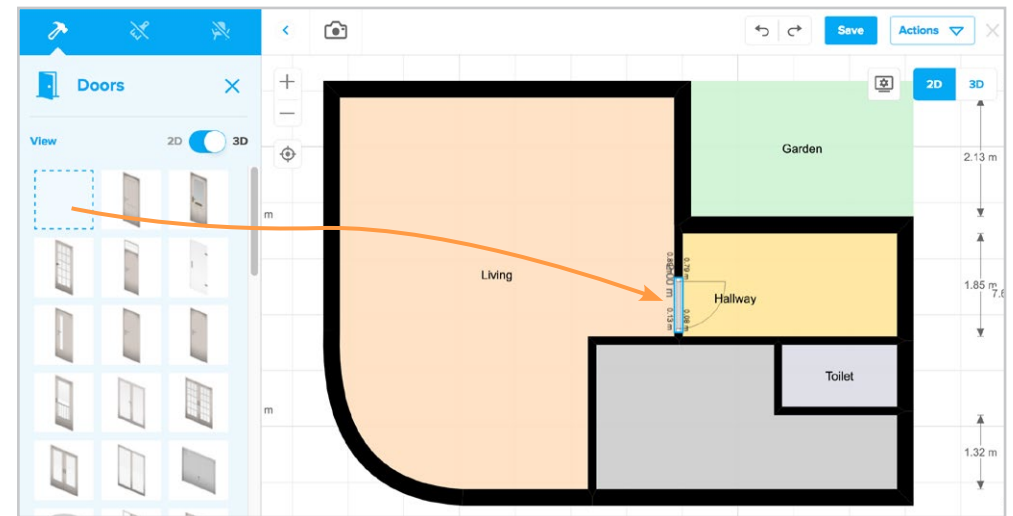

4) Click the door or window to adjust the wall side, hinge side and an option to duplicate and remove.



5) Set the width, height and raise from the floor in the side bar.

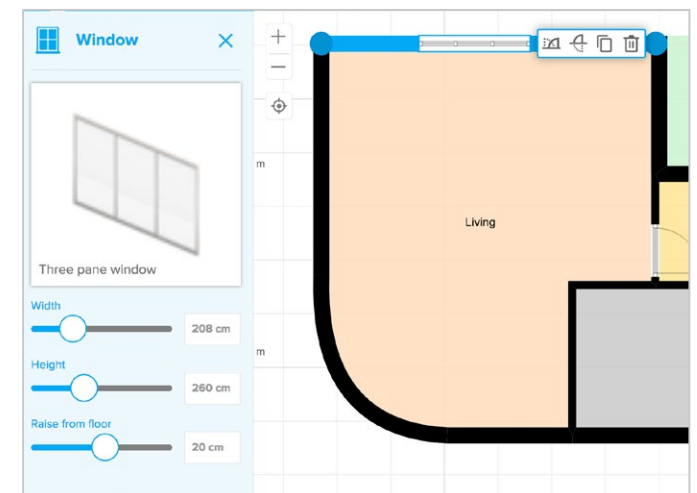

# 7d Build: Structures

The structures library has a selection of objects that can be used as architectural elements in your plan.

## Adding structures

1) Click on the structures icon

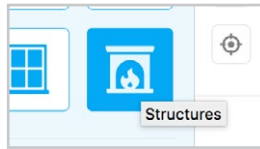

2) You can view the list of structures in 2D top view or 3D view.

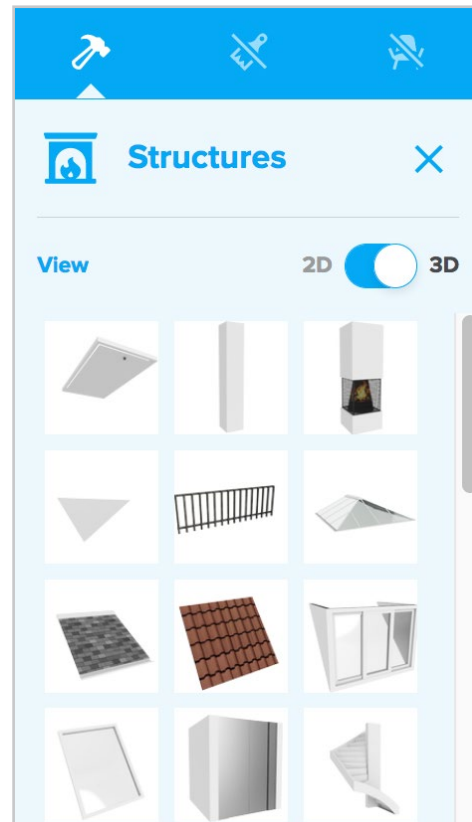
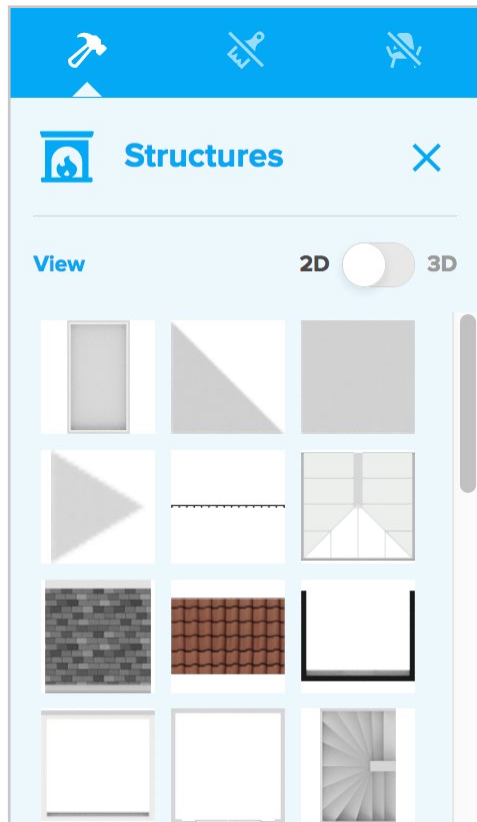

3) From the list, drag and drop your element into your plan.

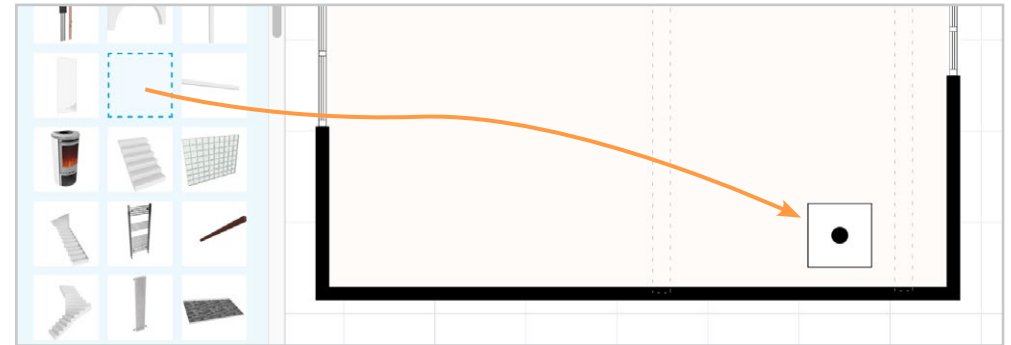

4) Click the item to adjust the dimensions, rotate or mirror the object.

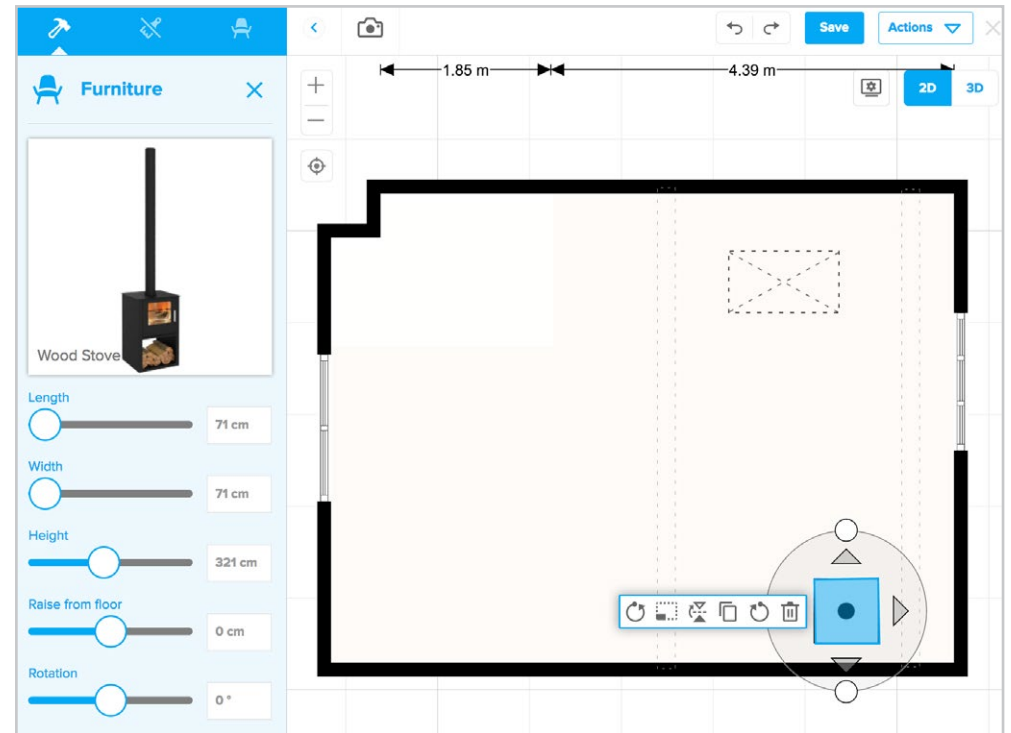

# 7d Build: Structures

5) Check in 3D or camera view your plan. In this example we used several elements from the structures set:

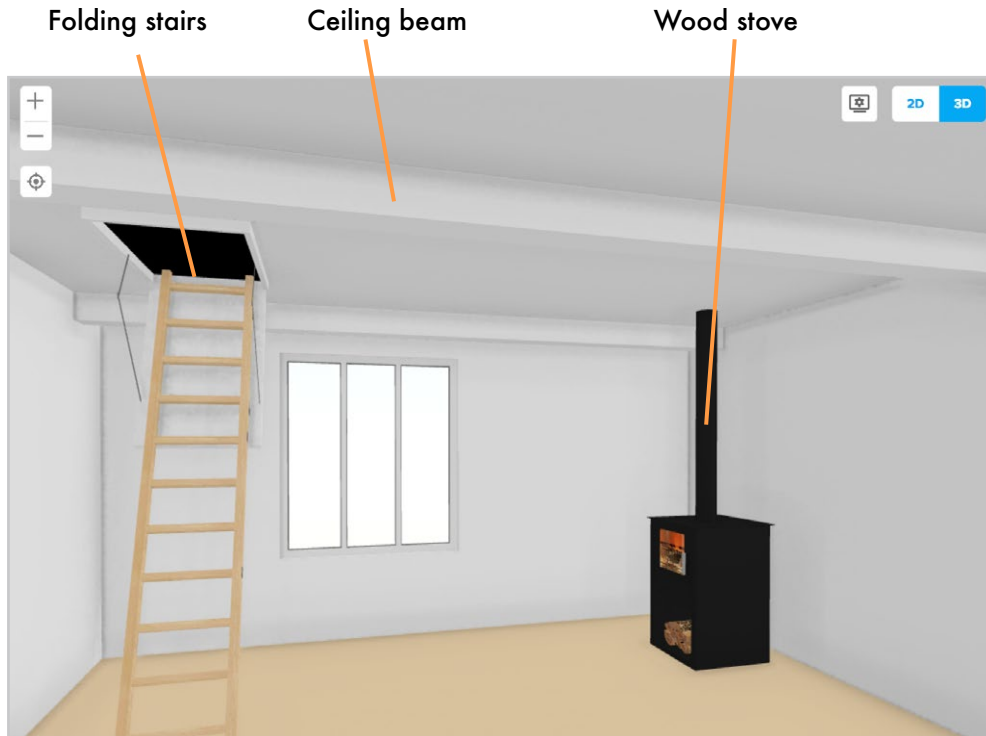

*Tip: the Structures is just a selection. We have much more achitectoral items in our furniture library divided in categories and subcategories. Search the architecture collections on for instance staircase or fireplace and you will get a lot more results.*

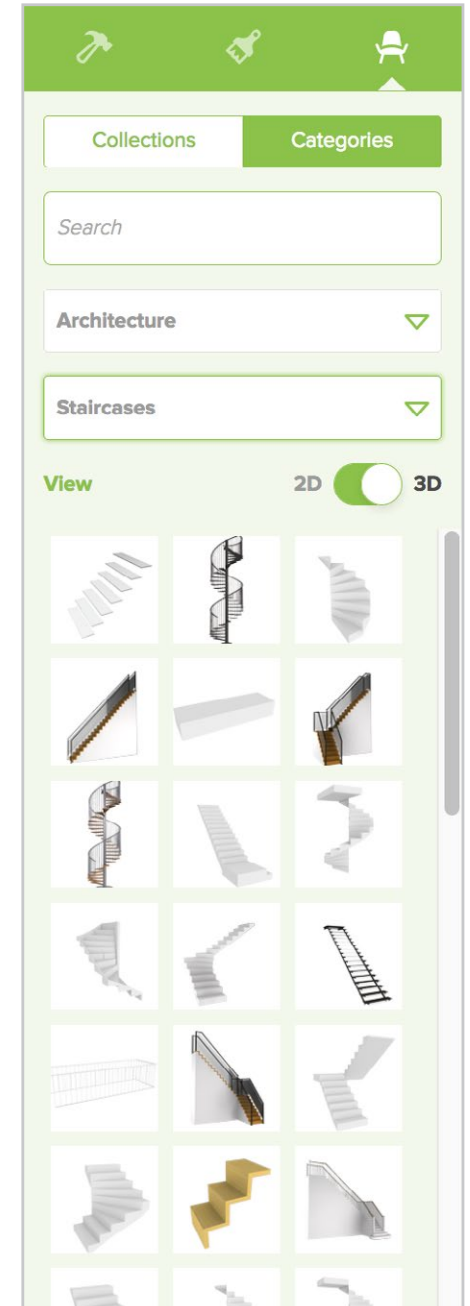

# 7e Build: Text Label

You can use a text label to add comments, or extra information to a plan. Text can be colored, rotated etc.

1) Click on the text label icon



2) Your text label appears directly in your plan and you can type and format your label in the sidebar.

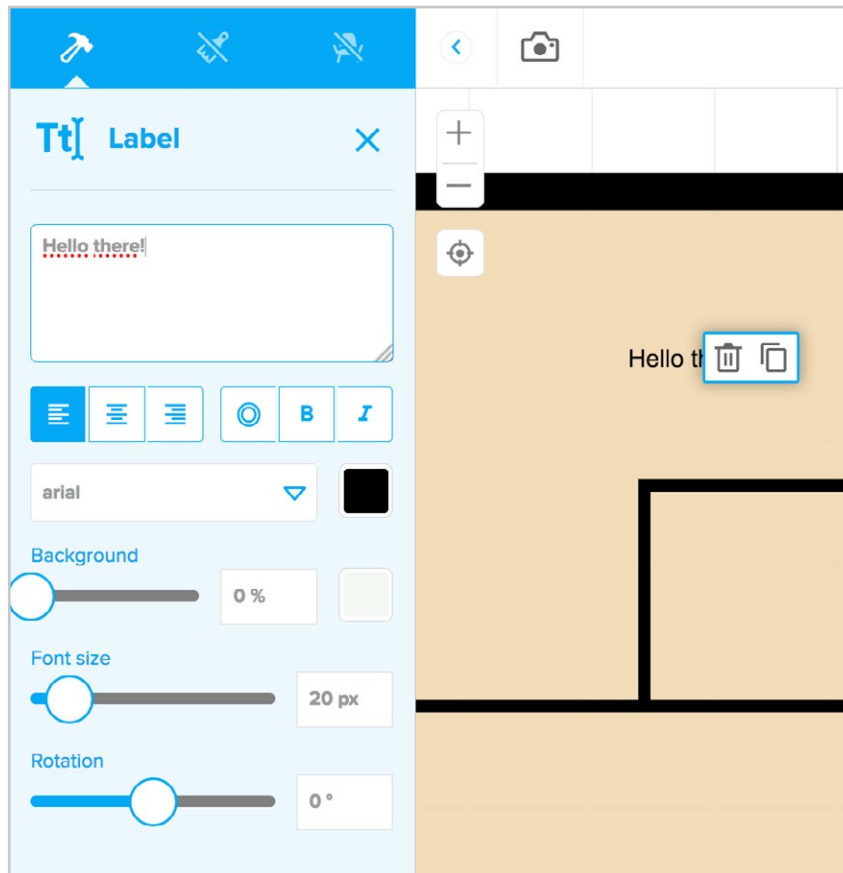

In the example we'll show where you can use text labels

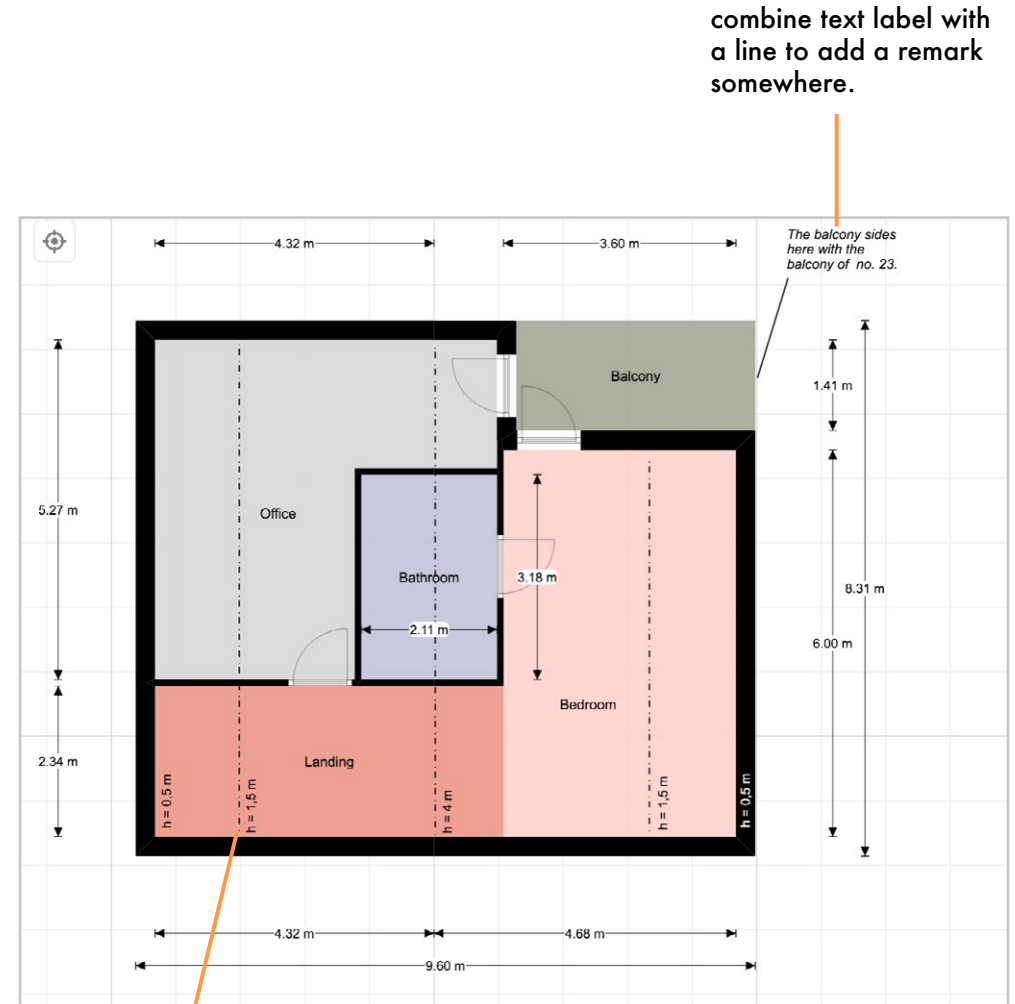

combine text label with a line to add a remark somewhere.

Use a rotated text label with a dashed line to indicate the height of a sloping ceiling.

# 7f Build: Lines

You draw lines to indicate something in your plan.

1) Click on the line icon or hit I

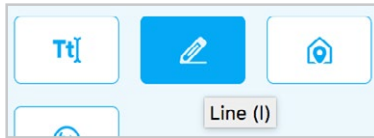

2) You can setup the line appearance the side bar. Click, drag and release in your canvas to draw your line.

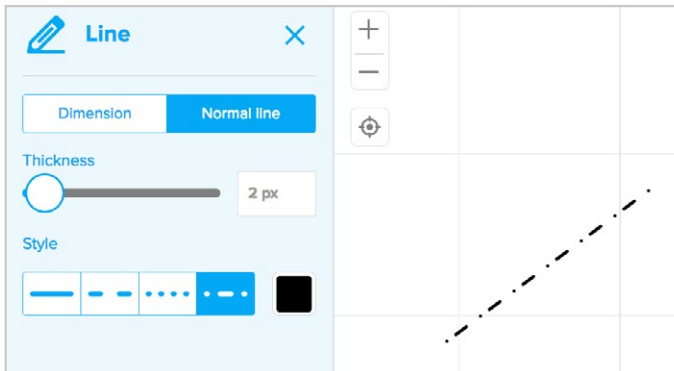

Tip: type in the length you want your line to be while you are dragging your mouse, and hit Enter to confirm.



3) Select a line to remove it with the trash bin, or change its appearance in the side bar.

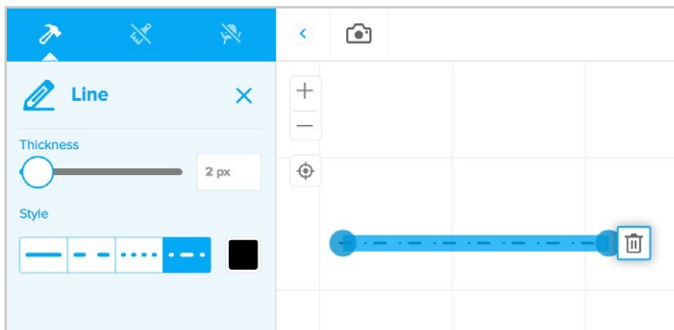

In an example we'll show where you can use lines

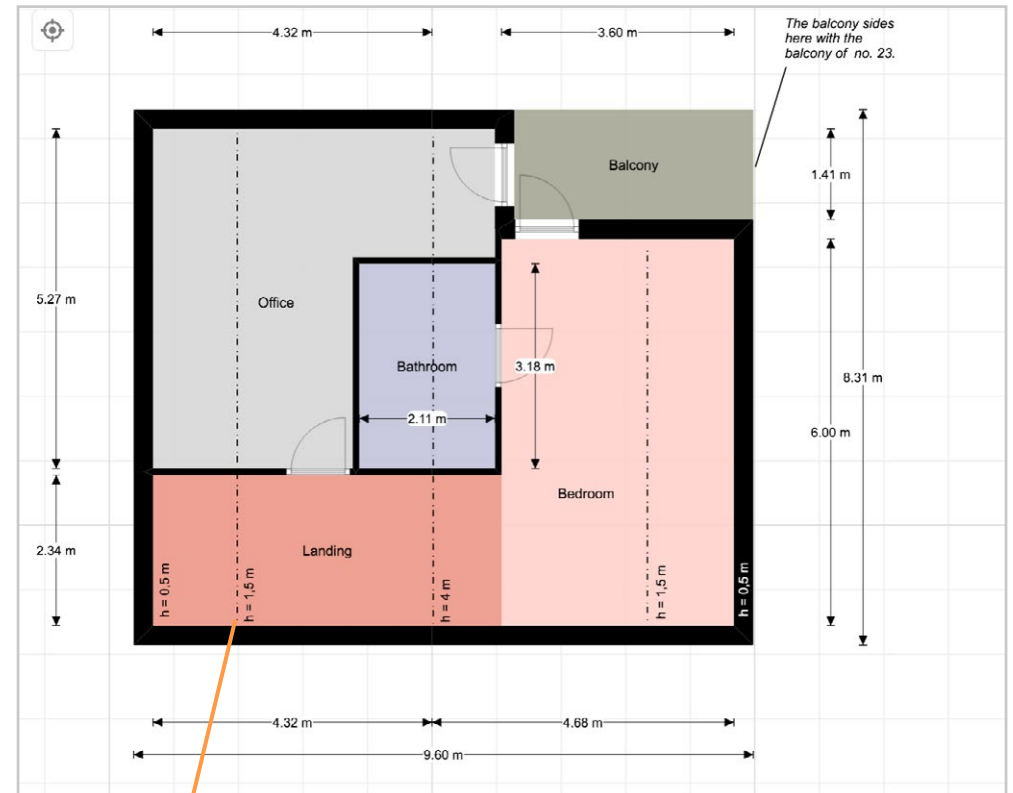

Use a dashdotted line to indicate the height of a sloping ceiling.

# 7g Build: Dimension lines

Floorplanner generates automatic dimensions around your walls. This will give you direct control over the size of your rooms, but also decrease the time you need for getting a dimensioned floorplan.

Mostly the auto generated dimensions will suffice. But sometimes you miss one or you want to alter the automatic dimension lines.

For adding a custom dimension line, see the next page.

If you're done with your plan, and you just want to change some of the auto generated dimension lines, then you can convert them all to custom dimension lines.

See page 35

You can change the room size by clicking on a dimension line and typing the size you need. Use one of the arrow buttons to indicate which wall to move.

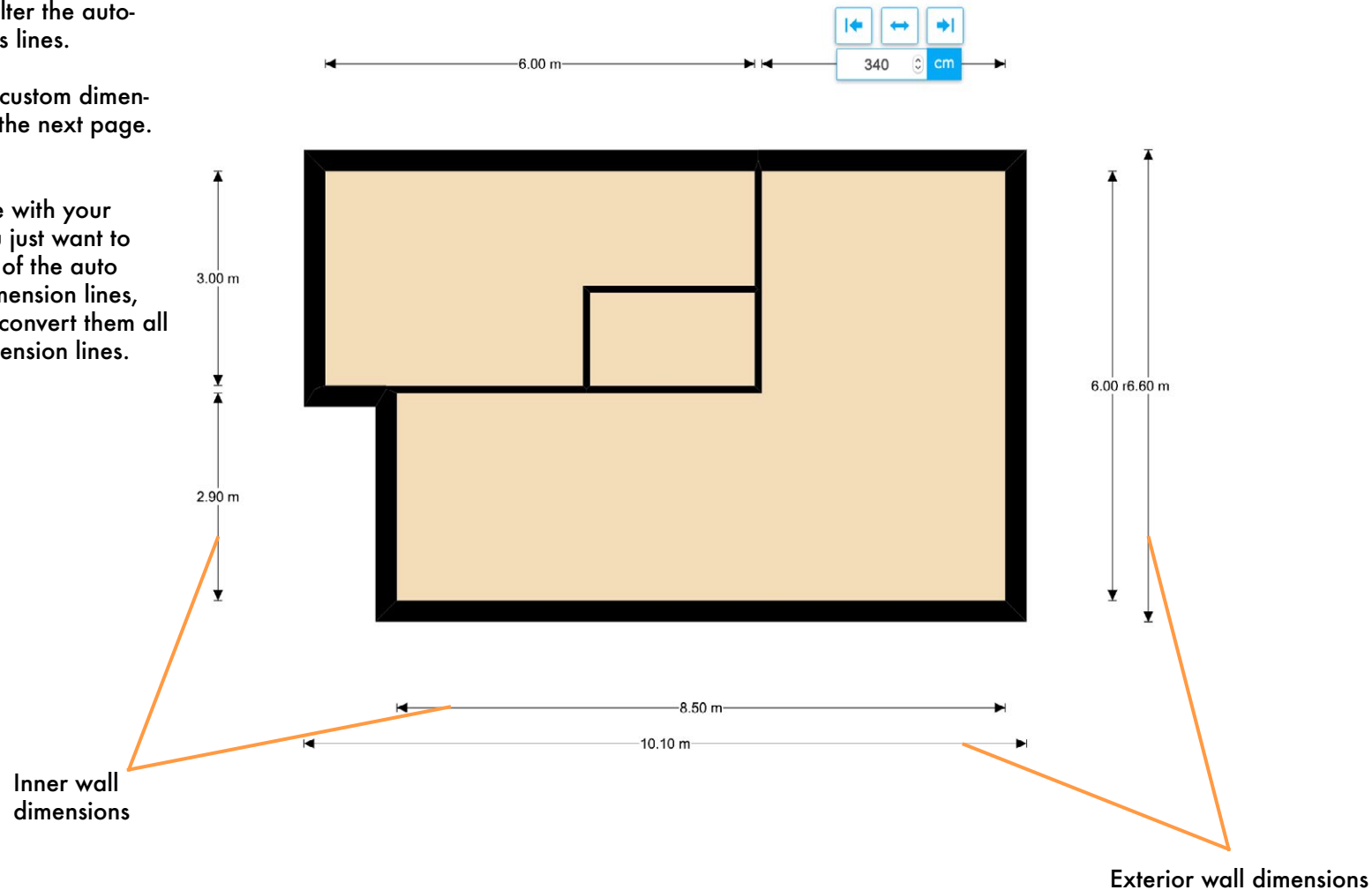

# 7g Build: Custom Dimension lines

You draw custom dimension lines if the automatic dimension lines don't show up where you want them to.

1) Click on the line icon or hit I

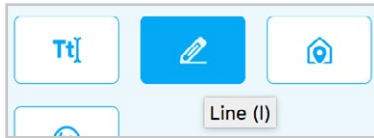

2) Select Dimension in the side bar

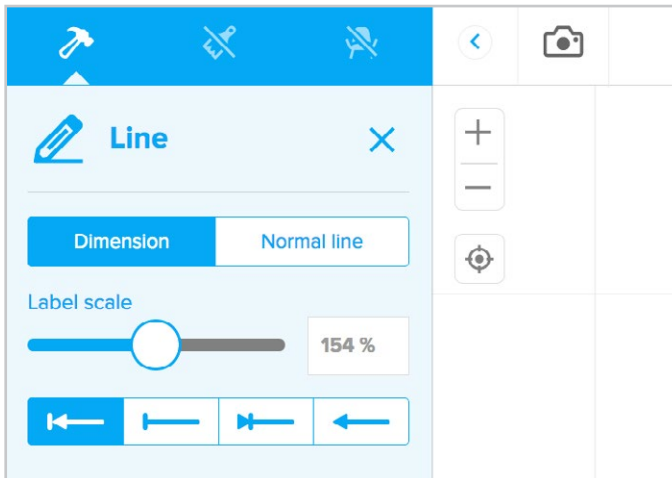

3) Draw a dimension line by click, drag and release in your canvas.

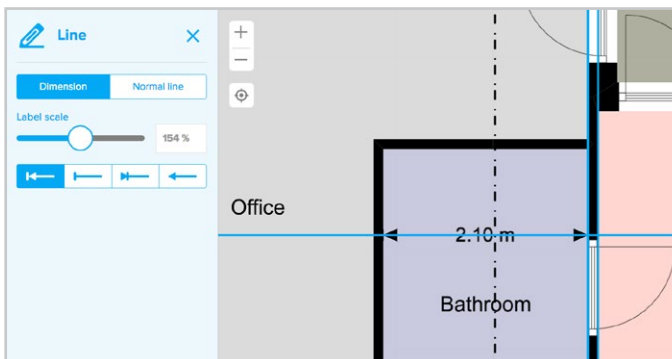

Tip: type in the length you want your line to be while you are dragging your mouse, and hit Enter to confirm.



In the example we show where you can use custom dimension lines to supplement the automated dimension lines.

Dimensions of rooms that don't appear as auto-dimensions, can be drawn as a custom dimension line.

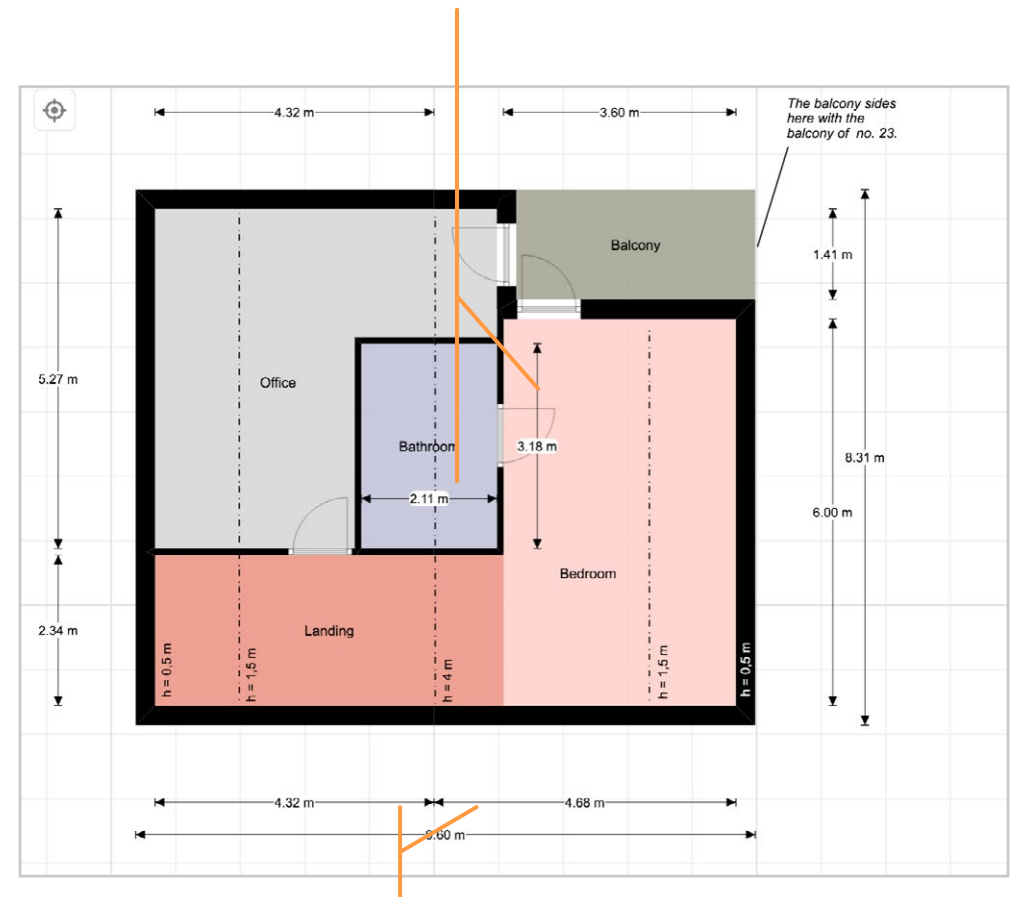

Some dimension lines like this one, you would want to merge. First convert your generated dimensions to separate dimension. (see page ...) Then you can delete one and modify the other.

# 7g Build: Custom dimension lines

You can change custom dimension lines after you draw them.

## Edit a custom dimension line

1) Click on the dimension line you want to change. Select the dimension value to edit.

*Tip: You can distinguish a custom dimension line from a generated dimension line by the blue dots on either side and the presence of a trashbin.*

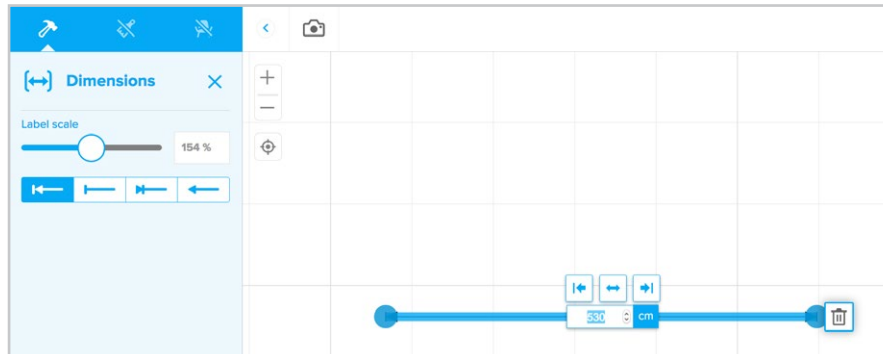

2) Type in the size you want the dimension line to be. Then click on one of the arrows buttons to move one of the arrowhead to its new position.

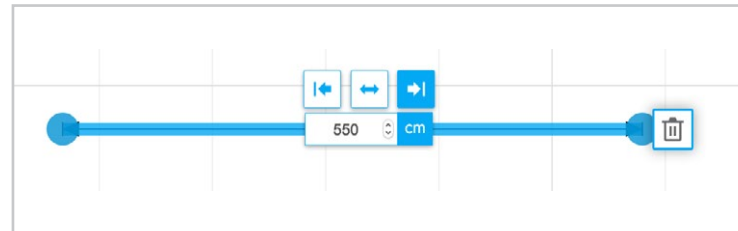

3) Your dimension is altered. You can also use the blue dots to move the line.

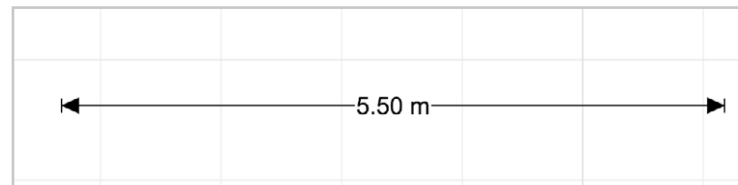

# 7h Build: Roomtypes

A floorplan with roomtypes assigned to each space is better readable. These roomtypes can also help you to find furniture for each room.

## Applying room types

1) Click on the roomtypes icon

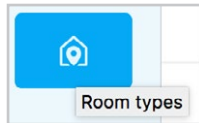

2) You can select a set of room types.

Tip: with a Pro account you can create your own set of room types that you frequently need.

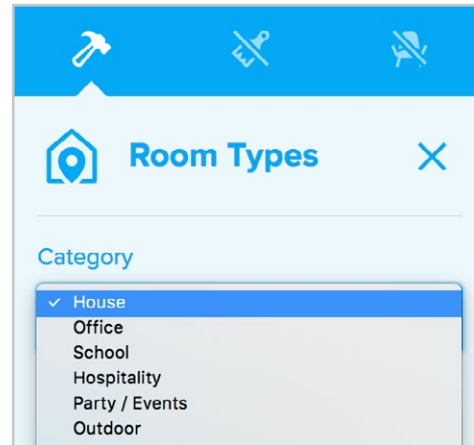

3) From the list, drag and drop your roomtypes onto the room surfaces.

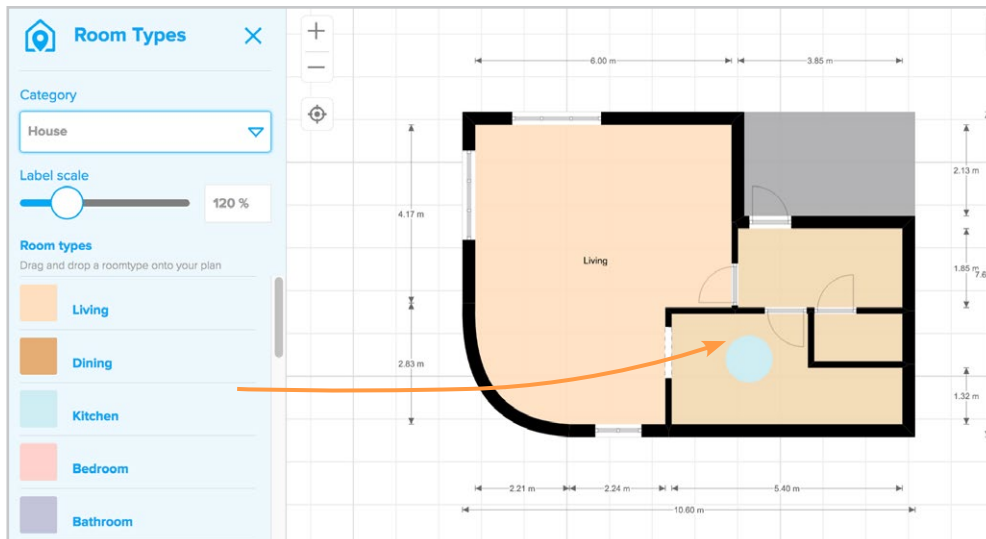

4) Apply as many room types as you need.

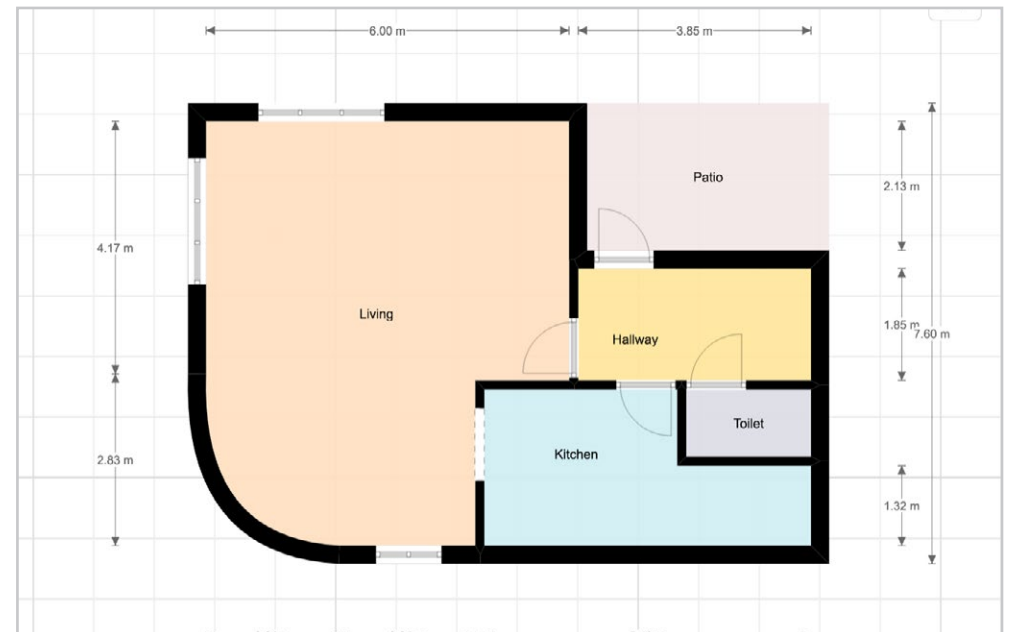

5) You can set the size of roomtypes to make readability even better.

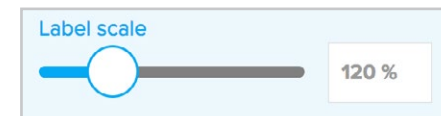

6) If you select a surface you'll find that you can remove a room type in the side bar.

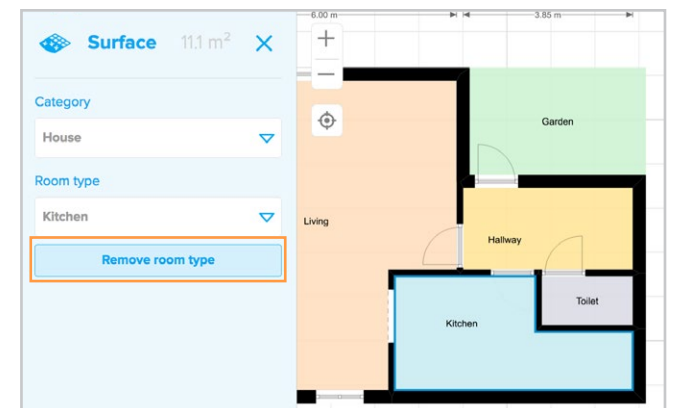

# 7h Build: Icons and Symbols

We have a library of symbols for electric plans, plumbing plans etc, and also a set of icons to make legends, create emergency plans or other purposes like wayfinding.

1) Click on the icon

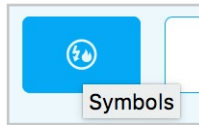

2) Select the set of icons you need.

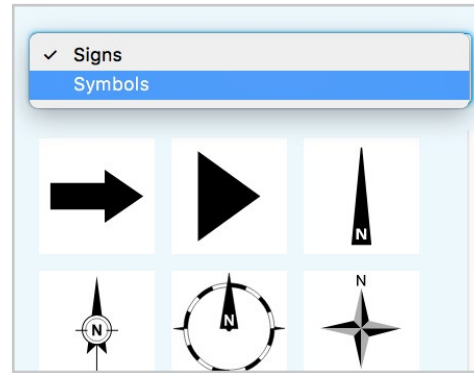

3) From the list, drag and drop your icon into your plan.

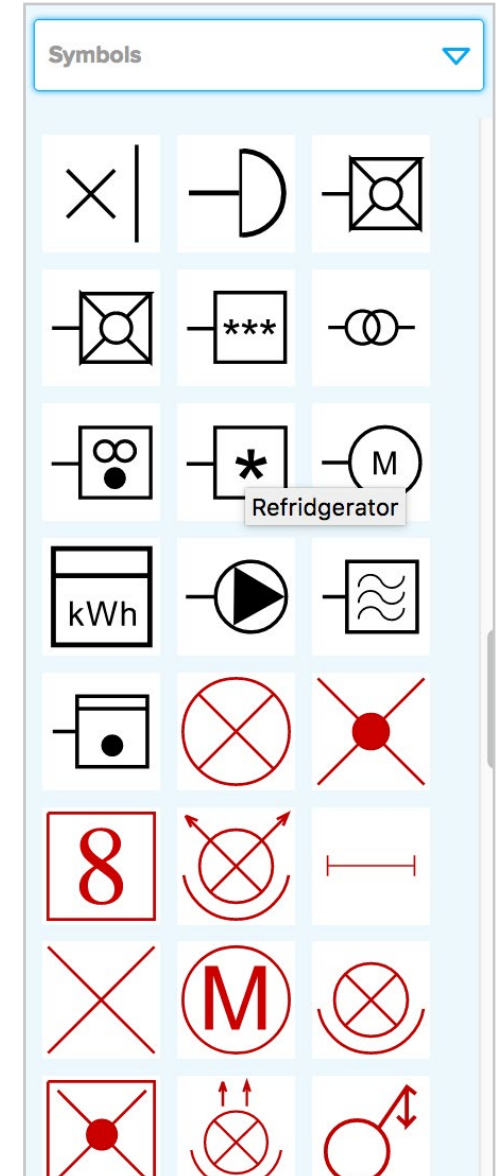
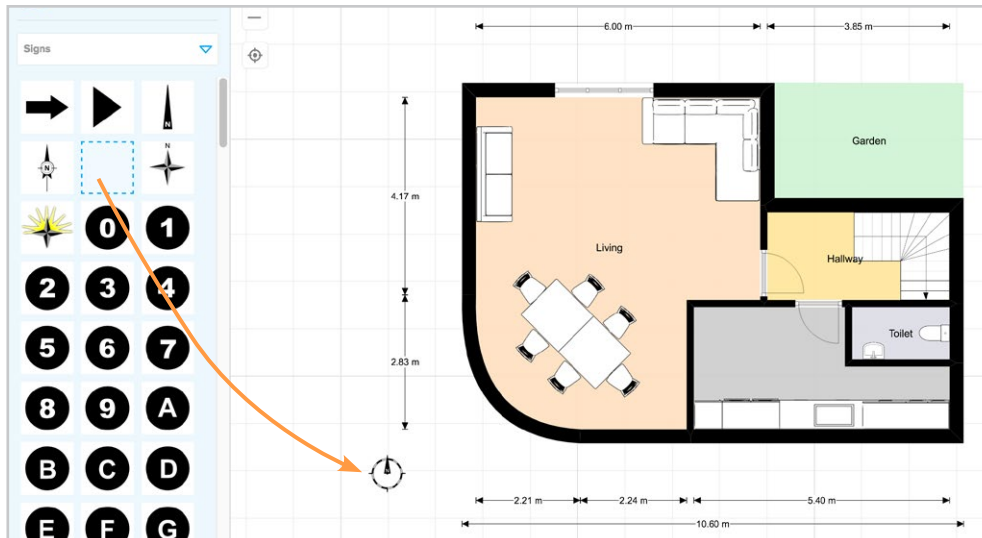

# 7j: Tape Measure

To measure a distance of anything in your plan, use the tape measure.

1) Click on the icon

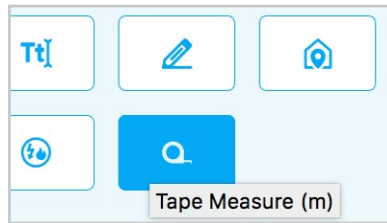

2) Click and drag anywhere in your plan to measure a distance.

*Tip: hold s to disable snapping*

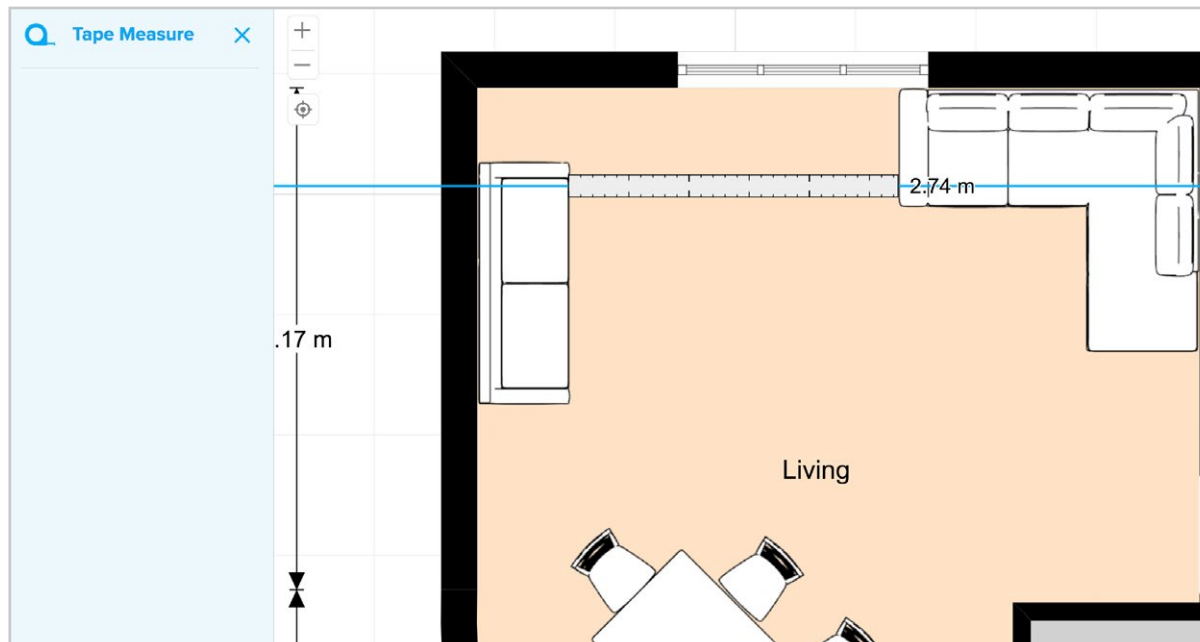

# 7k: Backdrop image

If you have an image of your floorplan already, you can upload it and trace it to draw your floorplan quicker and more accurate.

1) Click on the furniture tab

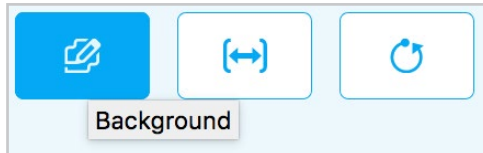

2) Click upload to your drawing

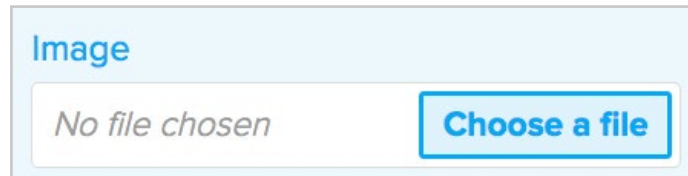

3) Navigate to your file and upload it. It has to be a PNG JPG or PDF image. You'll see these options:

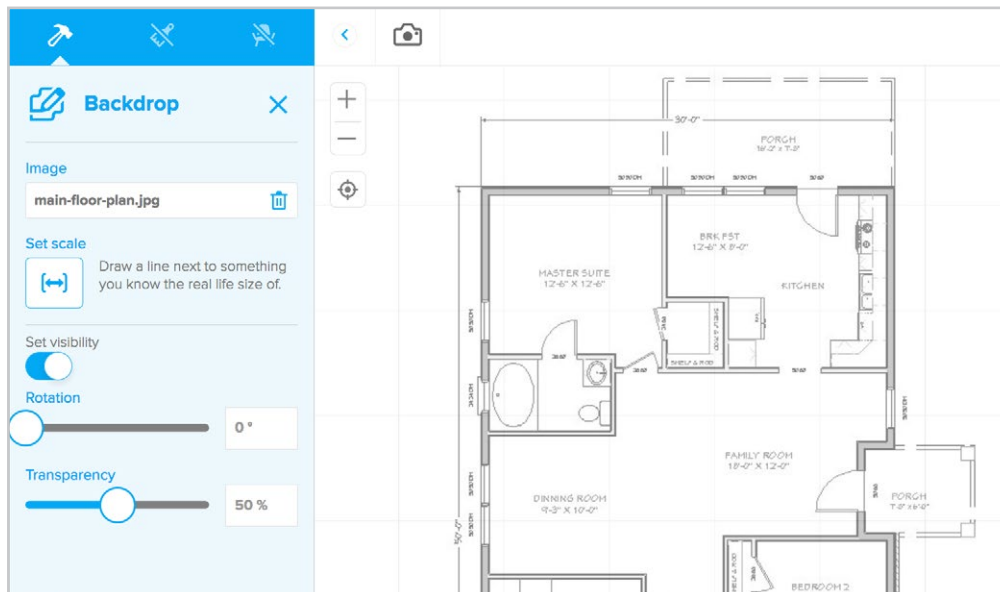

4) First rotate the image if necessary so most of the walls are horizontal and vertical. Set your units to meter or feet in the view settings.

Click Set scale to scale your drawing.

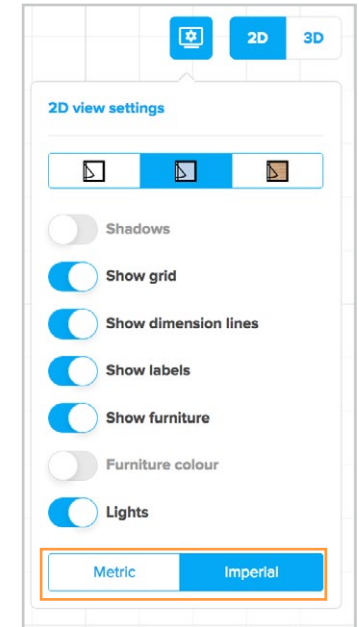
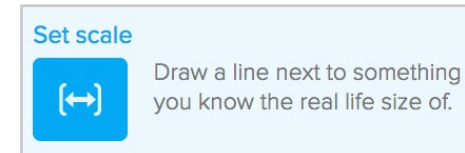

5) Zoom in to something in your plan of which you know the distance. Click on both sides of this element to draw a line and enter the distance and press OK.

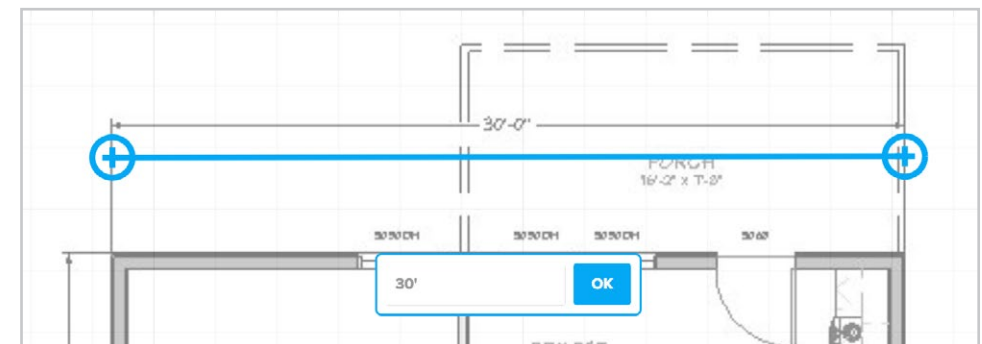

# 7k: Backdrop image

6) Now your backdrop is scaled. Zoom out to start tracing.

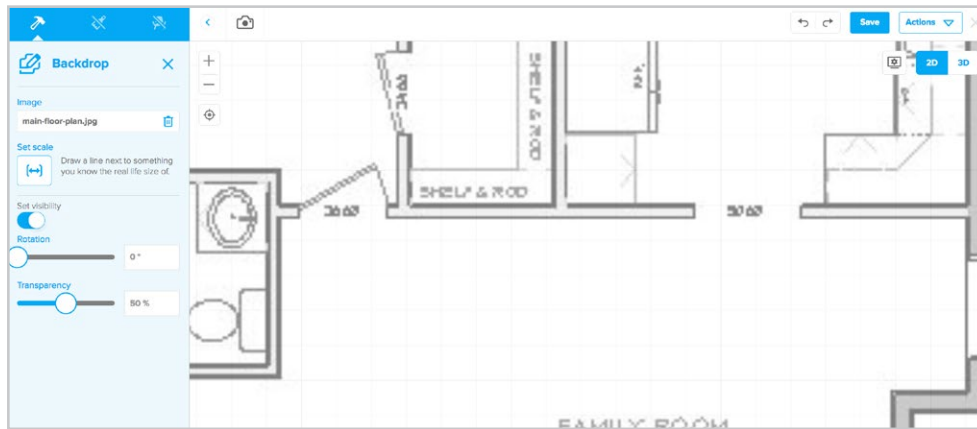

7) Click the room tool and set your wall thickness to correspond to the wall thickness of your exterior walls. Then start out by tracing the exterior walls. Proceed after that with your interior walls.

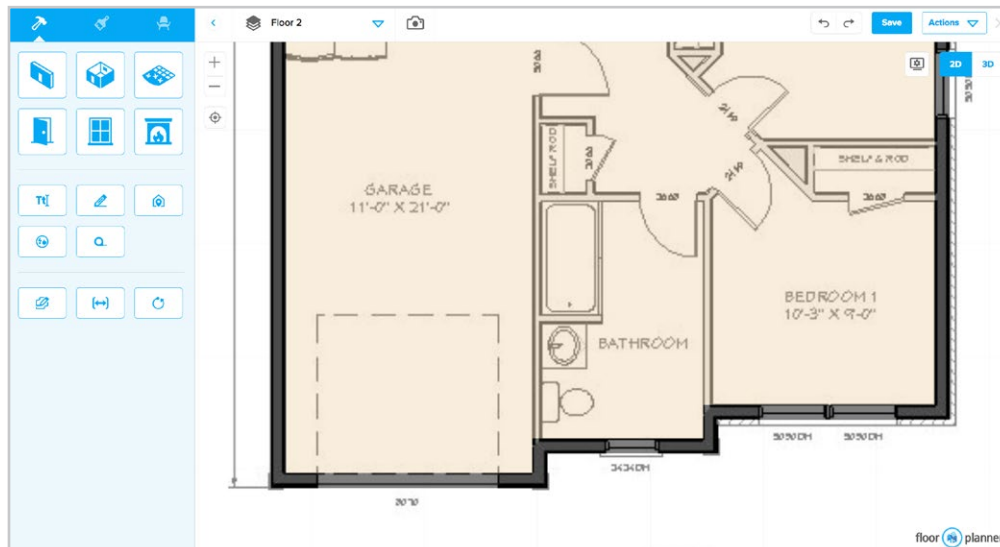

# 71: Dimension Settings

Floorplanner generates automatic dimensions around your walls. D

1) Click on the Dimension settings icon

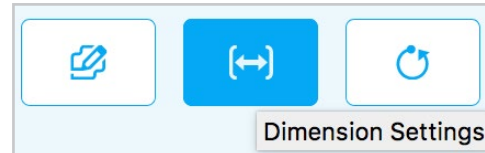

2) You can change the size and appearance of your dimensions in the top.

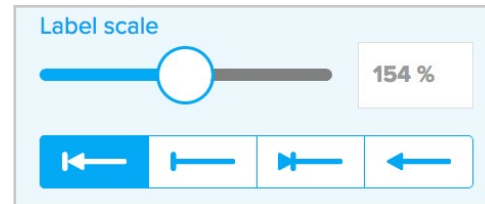

3) You can toggle this switch on and off to see which dimensions are auto-generated.



4) Convert your generated dimensions to custom dimensions with the blue button

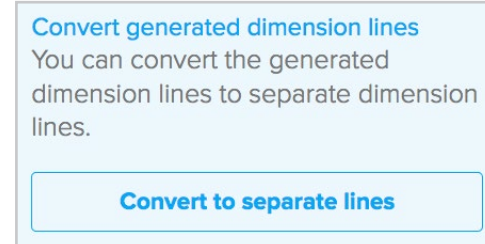

5) Now you can select and remove or modify the dimensions without affecting your rooms.

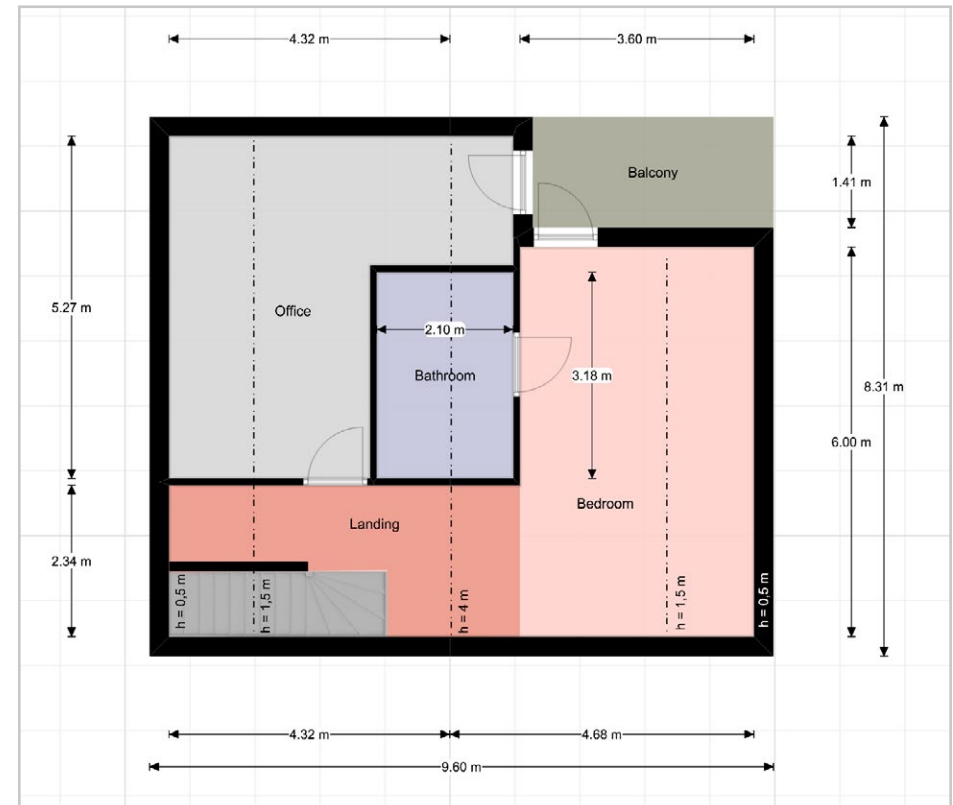

# 8a Decorate: Colors

Make your floorplan alive! You can apply colors or materials to rooms, surfaces and walls.

## Apply colors

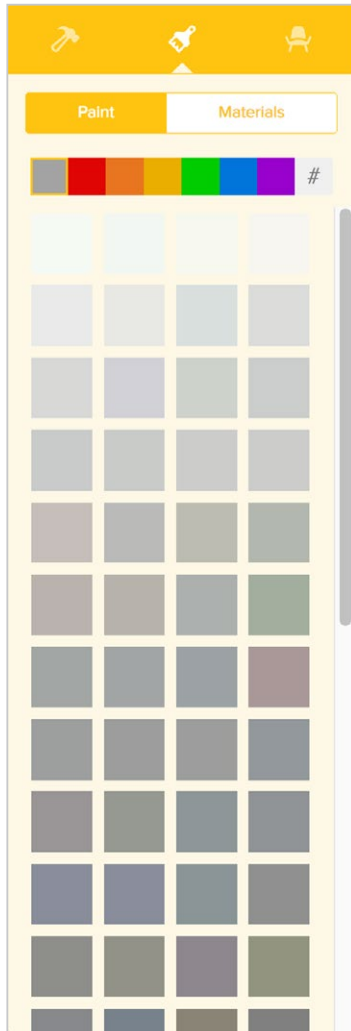

Find colors or materials, and apply them to a room, wall or surface.



# 8b Decorate: Materials

---

*To be continued...*

# 9a: Furniture library

We have a huge library of furniture items in floorplanner. You can find the items you need by doing a search, or by selecting a category to refine and sub category to refine your search.

1) Click on the furniture tab



2) Specify a search, like table or glass

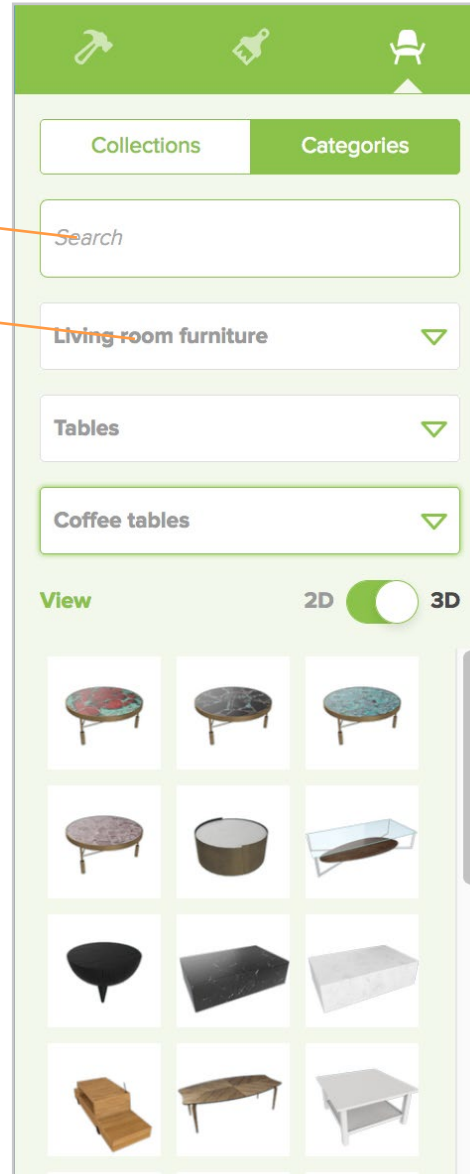

3) To narrow your search findings, select a category, and subcategory, or just scroll through the list.

4) Drag and drop an item into your plan.

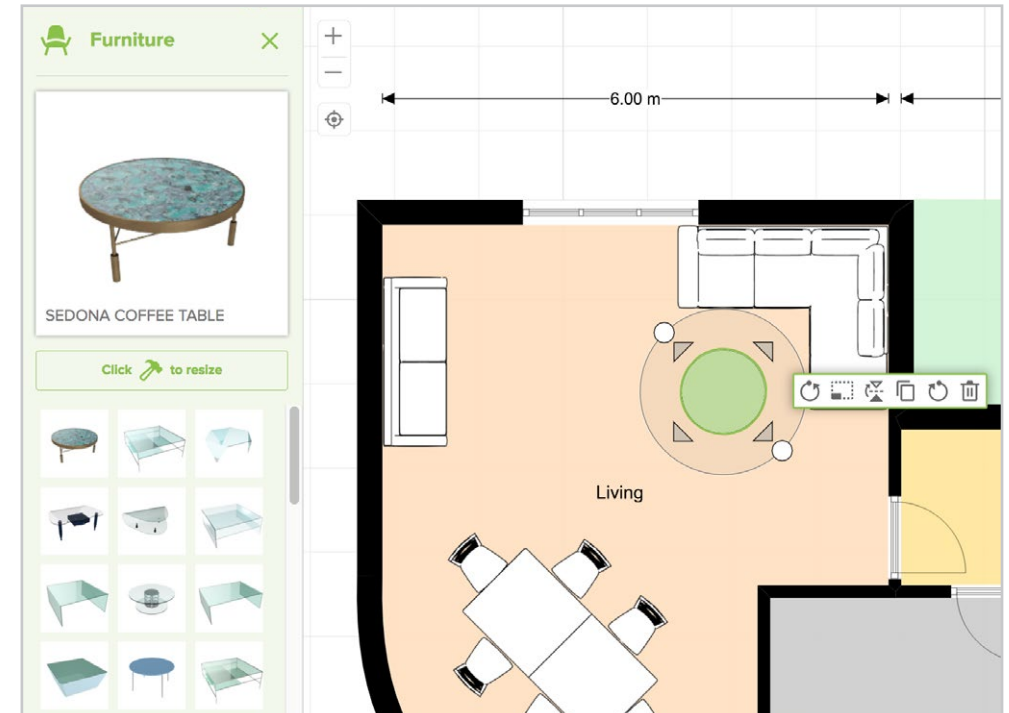

5) After you select this item, you can find related items in the sidebar, or click



to edit the dimensions.

# 9b: Selecting Furniture

You can select multiple pieces of furniture to perform quick actions on all of them.

There are 2 ways

- 1) Just click on multiple items after each other to make a temporary group.
- 2) Hold Shift and drag a rectangle around the items you want to add.

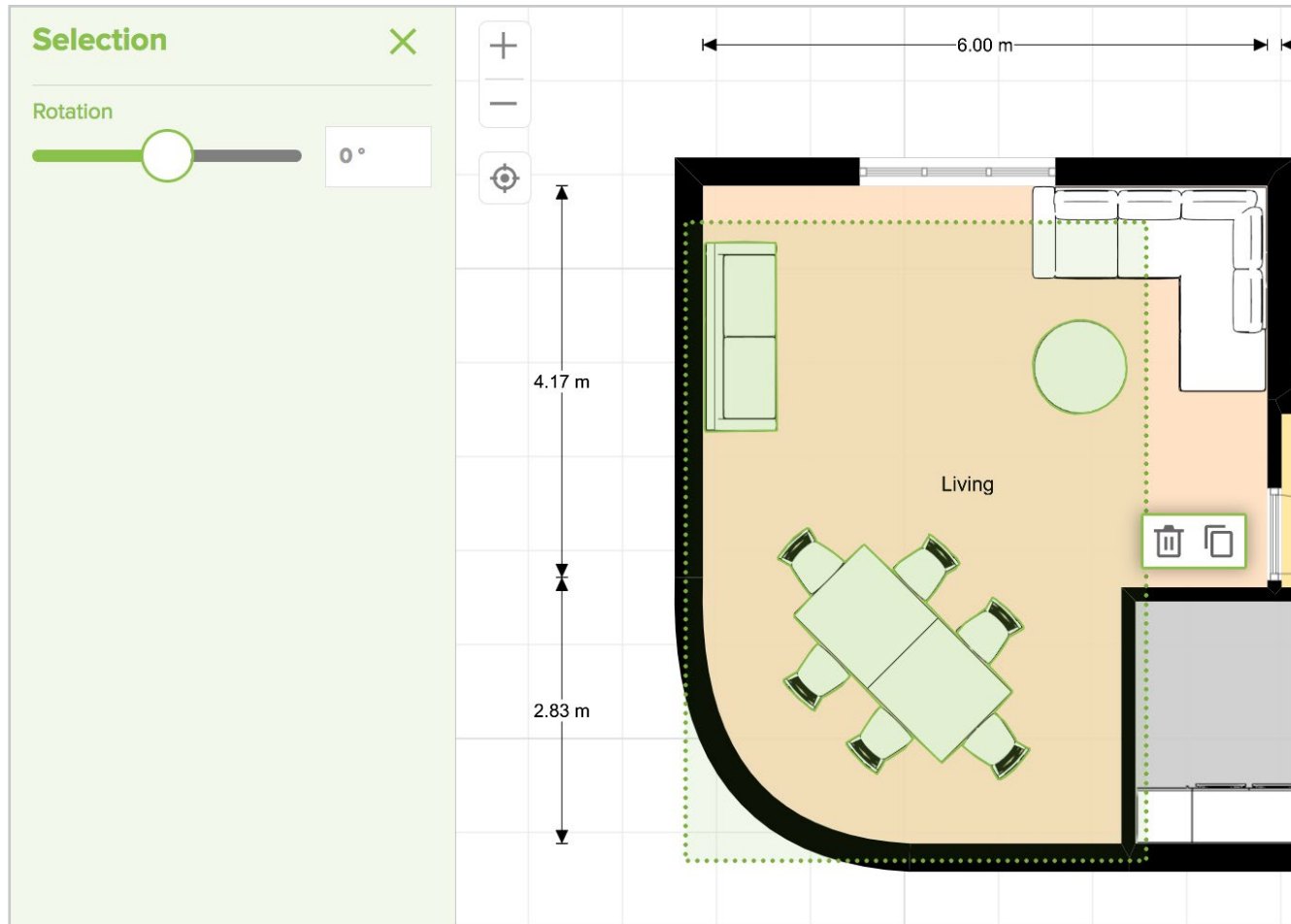

Now you can delete, or duplicate this group, or move it by dragging the rectangle, or rotate them with the slider.

# 10 Project Actions

When your floorplan is ready, there are several ways you can present or share it with others. These can be found under the Actions button.

1) Click on action button.

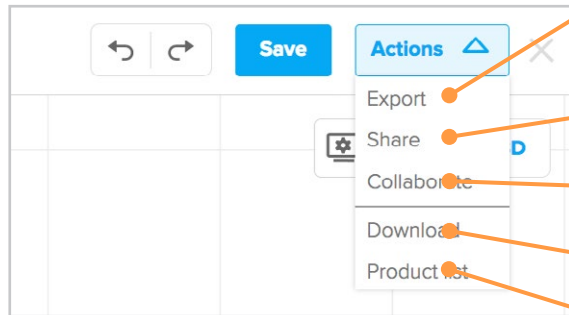

Export to 2D or 3D

Share a link to your floorplan, embed it in a website, or make it private

Collaborate on your plan with someone else

Download your plan as a .FML file

Get a list of products that you used in your plan.

# 10 a: Project Actions: Export 2D

You can export your plan to a 2D plan. Exports will be sent to an email address. Available formats are JPG, PNG or PDF.

Export

Scope:  Whole project  Current design

Title:

Format:  JPG  PNG  PDF

Orientation:  landscape  portrait

Images per sheet:  One  All

Ratio/Paper size:  A4  A3  A2  LETTER

Scale bar:  Yes  No

---

Export in 2D:   Scale to fit  1:24  1:48  1:64  1:96

Export in 3D:

Send email to:

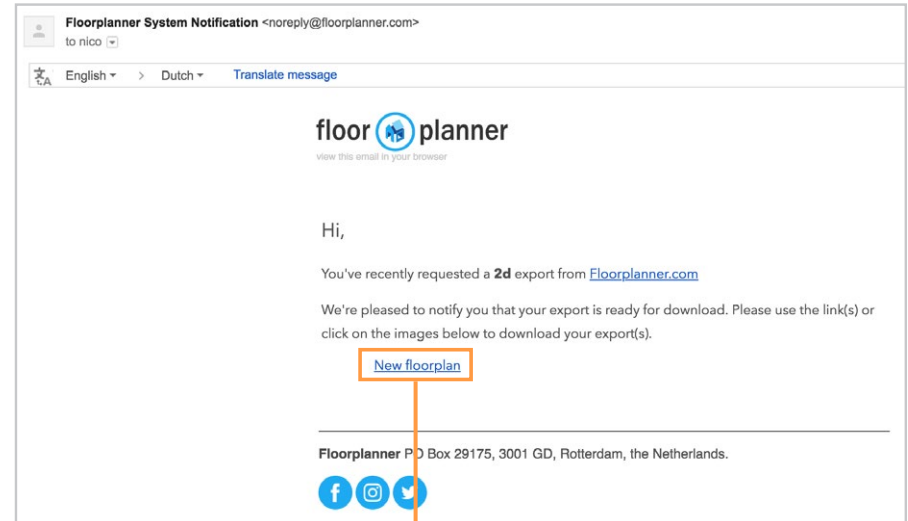

The export will show as your current view 2D settings.

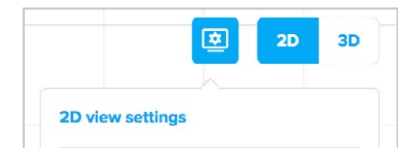

# 10 b: Project Actions: Export 3D

You can export your plan to a 3D plan. Exports will be sent to an email address. Available formats are JPG, PNG or PDF.

Export

Scope:  Whole project  Current design

Title:

Format:  JPG  PNG  PDF

Orientation:  landscape  portrait

Images per sheet:  One  All

Ratio/Paper size:  A4  A3  A2  LETTER

Scale bar:  Yes  No

---

Export in 2D:  Scale to fit:  1:24  1:48  1:64  1:96

Export in 3D:  Southwest

Send email to:

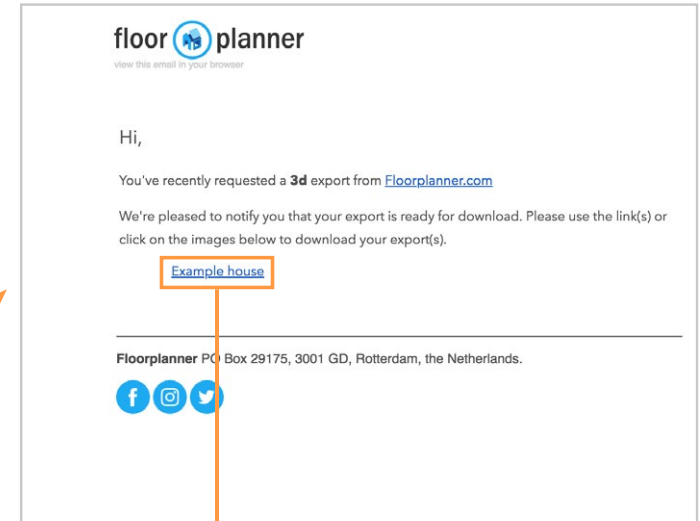



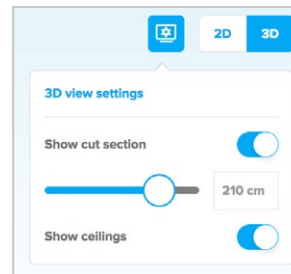

















The export will show as in your current view 3D settings.



# 11: Keyboard shortcuts

Learn to use these shortcuts to speed up your drawing. Some shortcuts are essential for drawing.

Function	Key(s)	Mode	Function	Key(s)	Mode
Exit mode		Drawing or selected item	Draw wall		In 2D view
Delete items	 or 	While item is selected	Draw room		In 2D view
Disable snap		Hold while drawing or moving stuff	Draw surface		In 2D view
Move around	   	In Camera or 3D view	Add text		In 2D view
Move item 1 step	   	While item is selected	Draw dimension		In 2D view
Rectangle select		Click and drag mouse in canvas	Draw line		In 2D view
Hide/show drawing		While tracing background image	Tape measure		In 2D view

*Tip: Get accustomed to hold 1 hand on your mouse, keep the other on your keyboard. Also, typing in values is usually quicker than using the sliders.*